



 **REGENCY**  
FIREPLACE PRODUCTS

*City Series*  
MODERN FIREPLACES  
WITH NO LIMITATIONS

# City Series

MODERN FIREPLACES WITH NO LIMITATIONS

The Regency City Series of modern gas fireplaces offer unmatched design flexibility, quality, and modern styling. These stunning fireplaces create a unique focal point in your home and provide the calming ambiance of a large fire with just the push of a button.

- TRUE FRAMELESS FIRE & SEAMLESS GLASS BARRIER
- PLACE A TV OR ARTWORK DIRECTLY ABOVE THE FIREPLACE WITH NO LIMITATIONS
- USE ANY MATERIAL RIGHT TO THE EDGE OF THE FIRE, EVEN WOOD OR WALLPAPER
- INDUSTRY'S BEST, MOST COMPREHENSIVE LIMITED LIFETIME WARRANTY



# Table of Contents

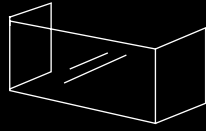

► <i>San Francisco Bay</i>	
ACB40E	04

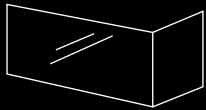

► <i>Chicago Corner</i>	
ACC40RE • ACC40LE	06



► <i>New York View</i>	
ACV40E	08

City Series Features	10
----------------------	----

Accessories	14
-------------	----

Specifications	19
----------------	----





*San Francisco Bay 40 shown with driftwood log set, black crystals, crushed coal black glass & reflective black enamel interior panels.*

# San Francisco Bay

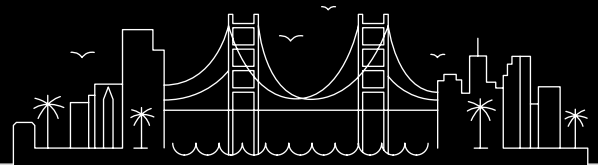

## ACB40E

Create the look you desire with flexible finishing options, linear design, and stunning log/crystal and flame picture. The San Francisco Bay sparks conversations and welcomes visitors to your home. Enjoy the comfort and ambiance of the unmatched City Series San Francisco 40.

### VIEWING AREA

WIDTH	HEIGHT	DEPTH
1194 mm	382 mm	375 mm



*San Francisco Bay 40 shown with starfire crystals, volcanic stones & matte black interior panels.*



*Chicago Right Corner 40 shown with black crystals, crushed coal black glass & reflective black enamel interior panels.*

# Chicago Corner

## ACC40LE • ACC40RE

Available as either a Left or Right corner unit with flexible venting options, the Chicago Corner 40 is perfect as a standalone design feature, or as a stunning accent in any room. Flexible installation, unlimited finishing options, and limitless potential is possible with the Chicago Corner 40.

### VIEWING AREA

WIDTH	HEIGHT	DEPTH
1092 mm	382 mm	375 mm







*Chicago Left Corner 40 shown with starfire crystals, & reflective black enamel interior panels.*



*New York View 40 shown shown with starfire crystals, volcanic stones & reflective black enamel interior panels.*

# New York View



## ACV40E

With its simple, elegant design the New York View 40 brings the flexibility and beauty of the City Series to any home. A frameless design and stunning flame picture are sure to continue grabbing your attention for years to come.

### VIEWING AREA

WIDTH	HEIGHT
1016 mm	382 mm





*New York View 40 shown with driftwood log set, black crystals, crushed coal black glass & reflective black enamel interior panels.*



*San Francisco Bay 40 shown with starfire crystals, volcanic stones & reflective black enamel interior panels.*

# Unlimited Finishes

## NO LIMITS. NO RESTRICTIONS.

Designed to stay cool with Regency's patented Cool Wall System to accommodate custom finishes right to the edge of your fireplace!

## ADVANTAGES

- Place a TV above the fireplace without it getting damaged
- Hang artwork without fear of warping
- Paint will not discolor, drywall will not crack
- No internal fans required
- Use any finish right to the edge of the fire, even wood or wallpaper



Wood



Wallpaper



Fabric

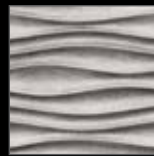

Textured Panel



Metal

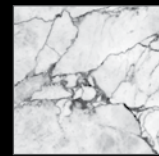

Marble



Tile



Embossed Panel



Glass

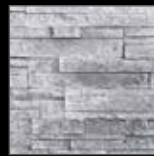

Faux Stone

## FRAMELESS FIRE

- An uninterrupted view of the flames
- Seamlessly integrates into any interior
- Patented invisible glass safety barrier
- No frames, mesh or silicone
- Multiple interior liner panel options
- Available in single-sided, two-sided and three-sided designs





# Controllable Warmth

## FLEXIBLE VENTING OPTIONS

Regency's patented Cool Wall System releases warmth at ceiling level. This system reduces excessive radiant heat in front of the fireplace so you can enjoy your fireplace more often.

- Design your own chase vent solution to suit your home
- Use optional front or side chase vent grills
- Release warmth into the room discreetly



Front



Side



Top

## COOL WALL SYSTEM

Cool air is drawn into the system around the floating glass safety barrier. Cooler air is then split between the heat exchanger and the inside wall surface.

The air travelling through the heat exchanger is heated by the fireplace and then directed out the back of the fireplace. The combined warmed air is then vented back into the room.





*New York View 40 shown with black crystals, crushed coal black glass, reflective black enamel interior panels & extended view panels.*



# Accessories

## EXTENDED VIEW PANELS

Flush to the wall and reflective, black glass extended view panels focus the eye, create visual balance and amplify flames for maximum impact. A literal expansion of City Series' frameless firebox, extended view panels integrate seamlessly for a striking, modern, linear look.

- Create the illusion of a larger fireplace
- Establish balance on a fireplace feature wall
- Black glass reflective finish amplifies the flame experience
- Can be used on New York 40 to extend the length by 24"

1



*In this photo, the fireplace is overshadowed by a large television, creating a top heavy fireplace feature wall*

2



*In this photo, the fireplace achieves visual prominence and balance with the addition of the extended view panels*

# ○ Create Your Own Fireplace



COMPACT CHASE FRAMING KIT



CORNER CHASE STARTER KIT

## OPTIONAL FRAMING KITS

	WIDTH	DEPTH	HEIGHT
Compact chase	1232 mm	476 mm	2032 mm - 3048 mm
Corner chase starter kit	1264 mm	457 mm	1597 mm Bottom of unit to top of framing kit

## REGENCY STEEL FRAMING KIT



## FIREBED OPTIONS



Black Crystals & Volcanic Stones



Starfire Crystals



Black Crystals & Driftwood Log Set



Black Crystals &  
Black Coal Crushed Glass

## INTERIOR OPTIONS

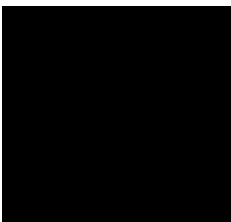

Matte Black Panels

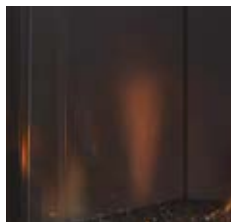

Reflective Black  
Enamel Panels



Accent Lights  
(Standard)

## REMOTE



Proflame II

## HEAT WAVE™ POWER DUCT SYSTEM

Increase the effectiveness of your fireplace by dispersing warm air from the fireplace to remote locations in the same room or other rooms in your home by using the heat wave power duct system.

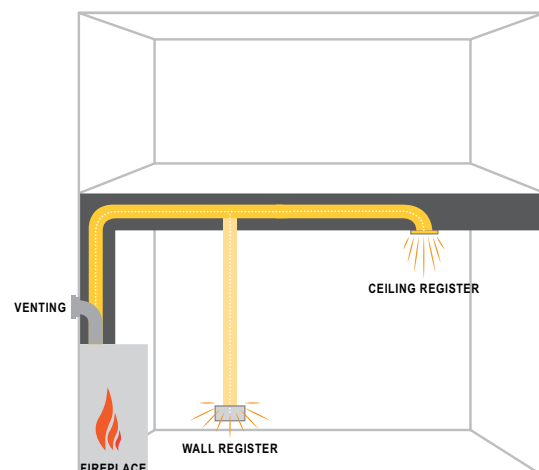



## ACCESSORIES

ACCESSORIES - AT A GLANCE			ACB40E	ACC40RE • ACC40LE	ACV40E
Clean face design			✓	✓	✓
Interior options	Firebed	Crystals in various colors	★	★	★
		Sea wool	✓	✓	✓
	For firebox floor	Black coal crushed glass	★	★	★
		Volcanic stones in various colors	★	★	★
	Log set	Driftwood log set	★	★	★
	Inner panels	Matte black	★	★	★
Black enamel		★	★	★	
Glass safety barrier			✓	✓	✓
Extended view side panels			•	•	★
Framing kits	Compact chase		★	•	•
	Starter kit		•	★	•
Chase grills	Front chase grill (304 sq. cm. opening)		★	★	★
	Side chase grill 2pk (304 sq. cm. opening)		★	★	★
Accent lights			✓	✓	✓
Controls	Proflame II GTMF		✓	✓	✓
Venting	Direct vent		✓	✓	✓
	AstroCap® venting system		★	★	★
	Heat Wave™ power duct system		★	★	★
	Heat Wave adapter		★	★	★
Conversion kit			★	★	★

- Not available
- ✓ Standard
- ★ Optional

## SPECIFICATIONS

### ► Natural Gas

SPECIFICATIONS - NATURAL GAS		NOMINAL MAX. GAS CONSUMPTION (MJ)	OUTPUT (KW)
San Francisco Bay	ACB40E	30 MJ/h	4.54
Chicago Corner	ACC40RE • ACC40LE	30 MJ/h	4.54
New York View	ACV40E	30 MJ/h	4.54

### ► Propane

SPECIFICATIONS - PROPANE		NOMINAL MAX. GAS CONSUMPTION (MJ)	OUTPUT (KW)
San Francisco Bay	ACB40E	30 MJ/h	4.54
Chicago Corner	ACC40RE • ACC40LE	30 MJ/h	4.54
New York View	ACV40E	30 MJ/h	4.54

### ► ULPG

SPECIFICATIONS - ULPG		NOMINAL MAX. GAS CONSUMPTION (MJ)	OUTPUT (KW)
San Francisco Bay	ACB40E	24 MJ/h	4.54
Chicago Corner	ACC40RE • ACC40LE	24 MJ/h	4.54
New York View	ACV40E	24 MJ/h	4.54

## ENJOY YOUR REGENCY — FOR LIFE

You'll be happy with your Regency for years to come, our Limited Lifetime Warranty guarantees it. Not only have we invested in quality workmanship, the finest materials and durable heavy-duty construction but we have carefully selected a dealer network that is committed to your satisfaction. All Regency gas fires pass stringent Australian testing standards. We know that you will be as proud of your Regency as we are.

Limited Lifetime Warranty covers the following components: Combustion chamber, heat exchanger, burner tubes and glass (thermal breakage).

**Refer to owner's manual for details.**



**NOTE: All product specifications are subject to change without notice. Before installing refer to the relevant product manual for full and up to date information. Stainless steel inner panels will naturally change tone over time. Heating capabilities of units are affected by: drafts under doorways or through flooring, large glass areas not covered by heavy drapes, ceiling heights greater than 2.4m or cathedral type ceilings, poor or no insulation and geographical locations.**

# Specifications (mm)

## San Francisco Bay units :

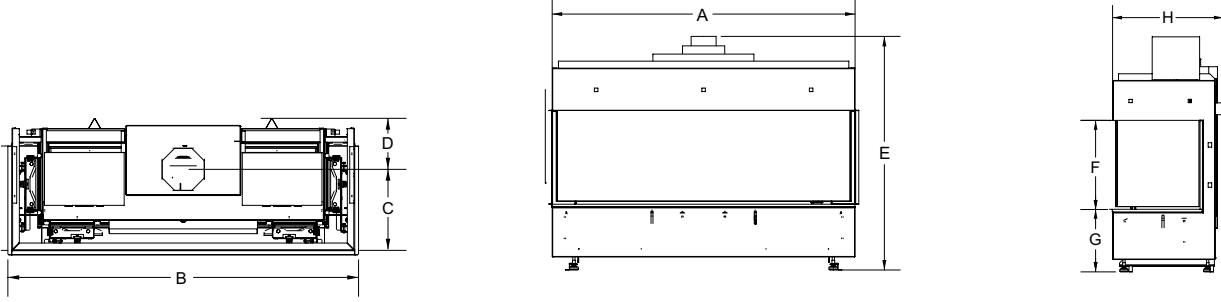

## Chicago Corner units :

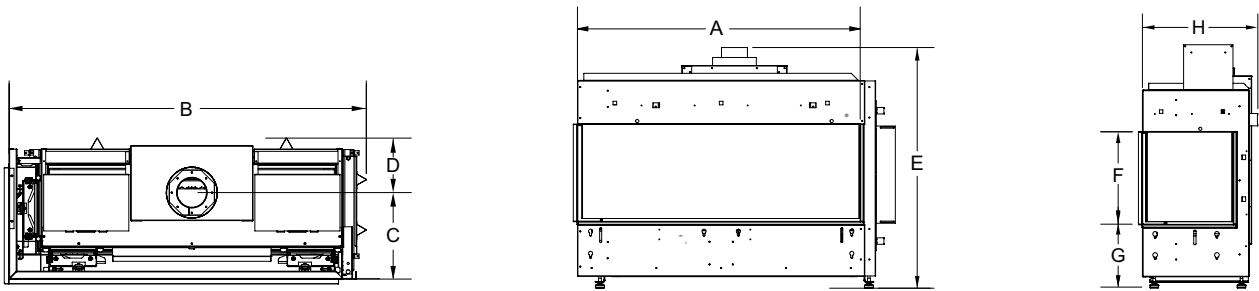

## New York View units :

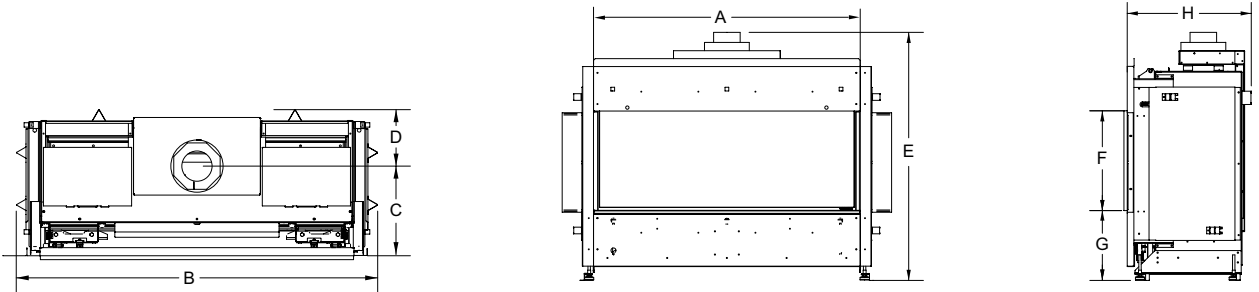

	ACB40E	ACC40RE • ACC40LE	ACV40E
A	1231 mm	1109 mm	1016 mm
B	1261 mm	1219 mm	1175 mm
C	291 mm	291 mm	291 mm
D	183 mm	183 mm	183 mm
E	946 mm	946 mm	946 mm
F	382 mm	382 mm	382 mm
G	267 mm	267 mm	267 mm
H	475 mm	475 mm	475 mm

UNITS	VENTING
ACB40E, ACC40RE, ACC40LE, ACV40E	10.2 cm x 17.5 cm

# CLEARANCES (mm)

## San Francisco Bay units :

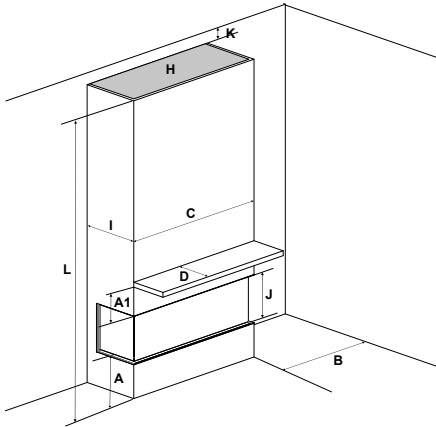

Floor to ceiling with top opening

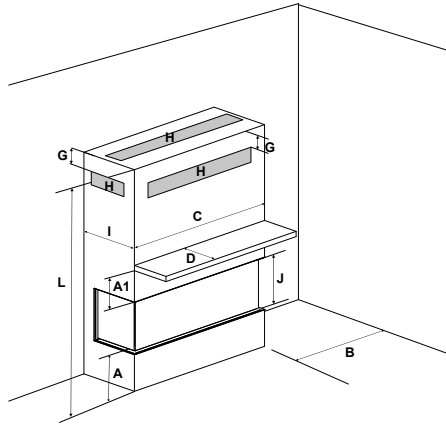

Low framing with vents in front/sides or top

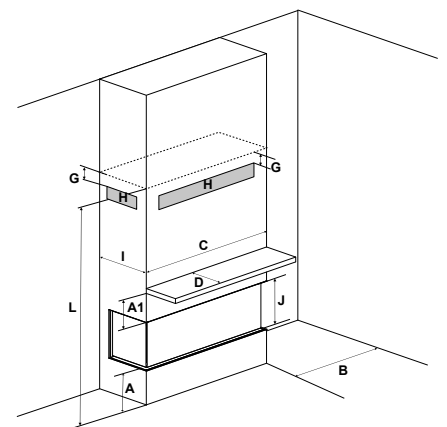

Full framing with low vents in front or sides

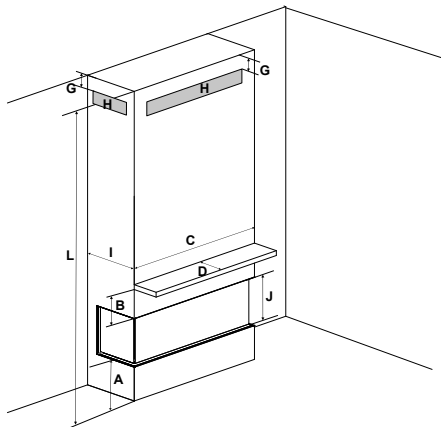

Full framing with vents in front or sides

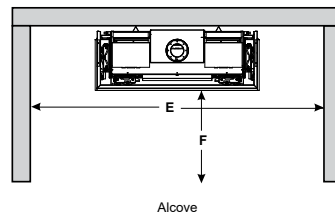

Alcove

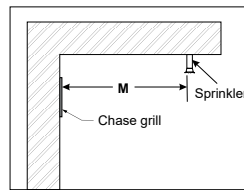

Side view

CLEARANCES		ACB40E
A1	From Floor	Min. 0 mm
A	Mantel Height (min.)	**
B	Sidewall (on one side)	216 mm
C	Enclosure Width (min.)	1230 mm
D	Mantel Depth (max.)	**
E	Alcove Width	2134 mm
F	Alcove Depth	914 mm
G	To Enclosure Ceiling (min./max.)	0 - 76 mm
H	Convection Air Outlet (min.)	*
I	Enclosure Depth (min.)	483 mm
J	Opening Height	383 mm
K	To Ceiling (min.) - All 3 sides	38 mm
L	Chase Enclosure (min.)	1600 mm

\* A minimum of 774 square centimeters of open area, not lower than 76mm from top of enclosure, required for all installations – this can be achieved by having an open area in front, each side, and/or above as shown in the four diagrams

\*\* See mantel clearances chart in the manual



# CLEARANCES (mm)

## Chicago Corner units :

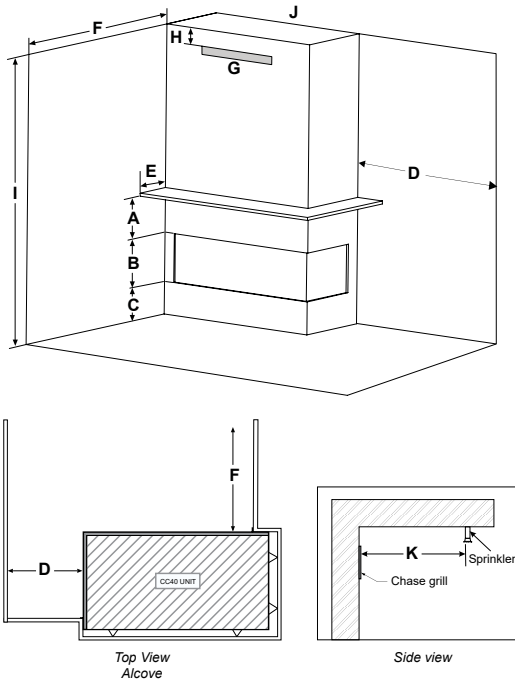

CLEARANCES		ACC40RE • ACC40LE
A	Mantel Height (min.)	**
B	Opening Height	382 mm
C	From Floor	Min. 0 mm
D	Sidewall (on one side)	Min. 914 mm
E	Mantel Depth (max.)	**
F	Alcove Depth	Min. 914 mm
G	Convection Air Outlet (min.)	*
H	Convection Air Outlet Opening Offset	0 - 76 mm
I	Chase Enclosure (min.)	1600 mm

\*A minimum of 774 square centimeters of open area, not lower than 76mm from top of enclosure, required for all installations

\*\* See mantel clearances chart in the manual

## New York View units :

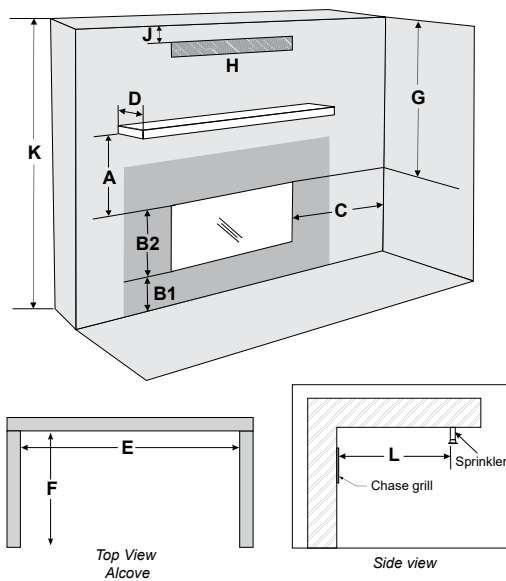

CLEARANCES		ACV40E
A	Mantel Height (min.)	**
B1	From Floor	Min. 0 mm
B2	Opening Height	383 mm
C	Sidewall (on one side)	216 mm
D	Mantel Depth (max.)	**
E	Alcove Width	2134 mm
F	Alcove Depth	914 mm
G	Ceiling (in front of fireplace)	953 mm
H	Convection Air Outlet (min.)	*
J	Convection Air Outlet Opening Offset	0 - 76 mm
K	Chase Enclosure (min.)	1600 mm

\*A minimum of 306 square centimeters of open area, not lower than 152mm from top of enclosure, required for all installations

\*\* See mantel clearances chart in the manual

# FRAMING (mm)

**San Francisco Bay units :**

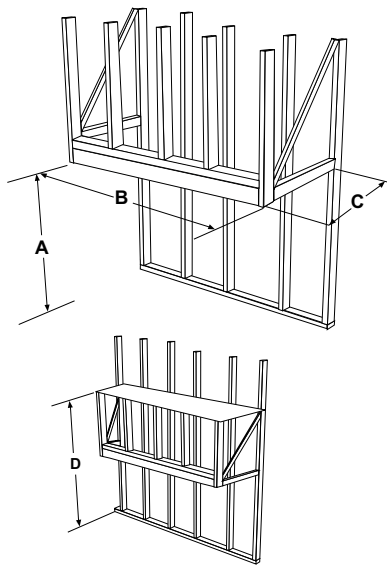

**Chicago Corner units :**

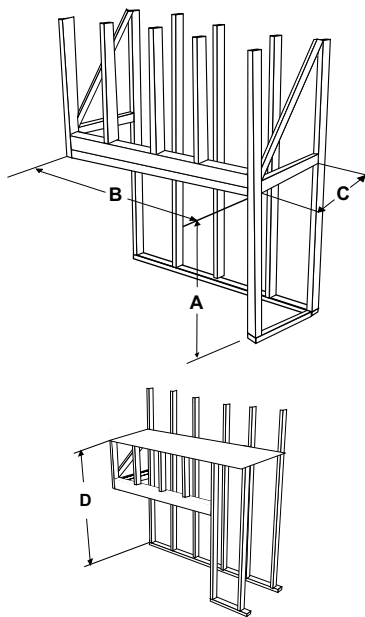

**New York View units :**

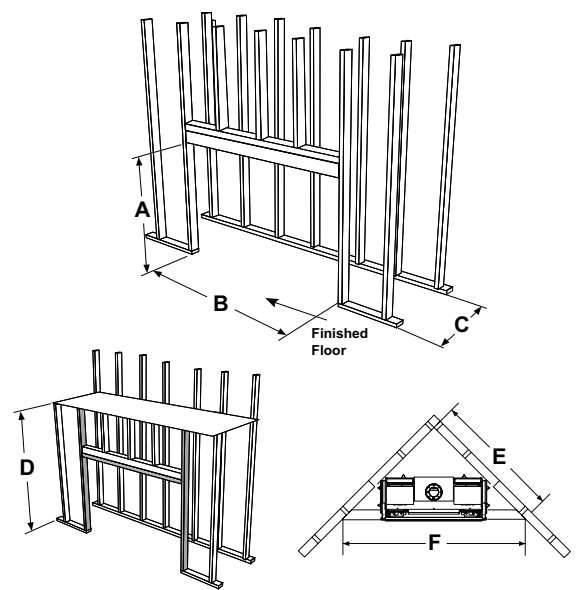

FRAMING	ACB40E	ACC40RE • ACC40LE	ACV40E
A Framing Height	949 mm	949 mm	949 mm
B Framing Width	1232 mm	1226 mm	1187 mm
C Framing Depth	483 mm	483 mm	483 mm
D Minimum Height to Combustibles	1600 mm	1600 mm	1600 mm
E Corner Wall Depth	-	-	1396 mm
F Corner Facing Wall Width	-	-	1974 mm

Visit [www.regency-fire.com.au](http://www.regency-fire.com.au) for City Series downloads including:

- Specifications
- Detailed drawings
- Manuals
- Framing & clearances



**regency-fire.com.au**

**FIREPLACE PRODUCTS AUSTRALIA PTY LTD.**

1 Conquest Way,  
Hallam VIC 3803, Australia

**Phone:** +1800 081 978

**Fax:** +613 9799 7822

**Email:** sales@regency-fire.com.au



**DISTRIBUTOR WA AIR GROUP AUSTRALIA**

28 Division Street,  
Welshpool WA 6106, Australia

**Phone:** +08 9350 2200

**DISTRIBUTOR NZ ABER HOLDINGS LTD.**

17 Mainstreet Place, PO Box 10095,  
Te Rapa Hamilton 3241, New Zealand

**Phone:** +64 7849 7585

*Your Regency Dealer*

©2020 FPI Fireplace Products International Ltd. Regency®,  
AstroCap® and Heat Wave™ are registered or proprietary  
trademarks of FPI Fireplace Products International Ltd.

All rights reserved (02/20)

Part No. 944-440