

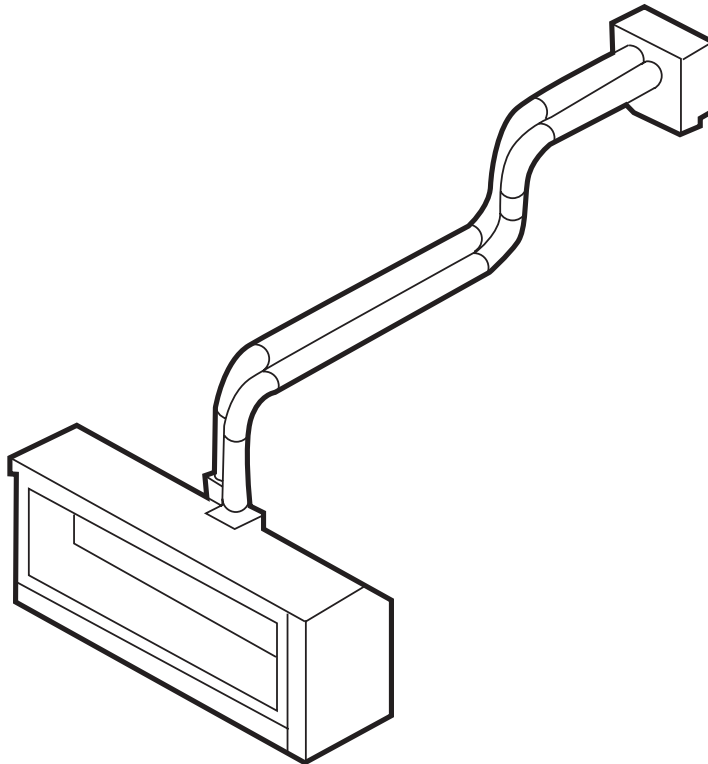

real flame

Leaders in
Gas Fireplace
Technology



ELEMENT FLAME EFFECT SPACE HEATER

INSTALLATION & OPERATING MANUAL

The Real Flame Element space heater is suitable to be installed into a frame out installation.

Designed to operate on Natural gas, LPG and ULPG gas.

Approval no.GMK 10441

VERSION 4

WARRANTY INFORMATION

The benefits provided to you under the following warranty are in addition to any other rights and remedies available to you under the law.

1. Warranty

If:

- (a) during the first 15 years from the date of purchase (Firebox Warranty Period), there is a defect in the firebox of the Real Flame Gas Burner; or
- (b) during the first 2 years from the date of purchase (Parts Warranty Period), there is a defect in the gas valves or other parts of the Real Flame Gas Burner,
due to improper workmanship or material, Real Flame will replace or repair the Real Flame Gas Burner without charge. Any replacement product is warranted only for the time remaining on the original Firebox Warranty Period or the Parts Warranty Period as relevant.

2. Registration

You must register to receive the benefit of this warranty by completing the warranty registration on our website (www.realflame.com.au) or completing and mailing the attached registration card within 30 days of purchase of your Real Flame Gas Burner (or, if the Real Flame Gas Burner is fitted to a new home, within 30 days of the date of settlement of purchase of such new home).

3. Exclusions

Real Flame is not obliged to replace or repair the Real Flame Gas Burner under clause 1 if:

- (a) it has been improperly stored, installed, connected, used, operated or repaired, or damaged, abused, tampered with, altered (without our written approval), or not maintained in strict accordance with our installation and operating instructions; or
- (b) it has been installed in an outdoor setting.

4. Limit of Liability

The warranty provided under this warranty is limited to replacement or repair of the Real Flame Gas Burner only, at our option. To the extent permitted by law, Real Flame excludes liability for consequential loss or any other loss or damage caused to property or persons arising from any cause whatsoever, and damage arising from normal wear and tear.

5. Claiming under the Warranty

In order to claim under this warranty you must, within the Firebox Warranty Period or the Parts Warranty Period (as relevant), contact Real Flame, providing the original proof of purchase and the details below:

Supplier Name _____

Date Of Purchase / settlement of property if new home _____

Model / Serial Number _____

This warranty does not cover the cost of claiming under the warranty or transporting the Real Flame Gas Burner to and from the supplier.

Our goods come with guarantees that cannot be excluded under the Australian Consumer Law. You are entitled to a replacement or refund for a major failure and for compensation for any other reasonably foreseeable loss or damage. You are also entitled to have the goods repaired or replaced if the goods fail to be of acceptable quality and the failure does not amount to a major failure.

If you would like to speak to someone about your Real Flame Gas Burner or claiming under this warranty, please contact the Real Flame Service Warranty Desk on 03 8706 2000.

Real Flame Pty Ltd ACN 006 311 155

Head Office: 1340 Ferntree Gully Road, Scoresby 3179

Telephone: 03 8706 2000 Facsimile: 03 8706 2001

WARNING

The Element space heater has a primary safety glass fitted in front of the glass door. This safety glass is fitted to this appliance to reduce the risk of injury from burns and at no time should this glass be permanently removed.

For protection of young children or the infirm, a secondary guard is required.

WARNING

The outer glass panel gets extremely hot! Precaution should be taken and young children supervised at all times when heater is operating.

INSTALLATION NOTICE

- The installation of this appliance is only to be carried out by an authorised person in accordance with the Manufacturer's Instructions, local gas fitting regulations, AS/NZS5601.1-2013 installation code for gas burning appliances and any other relevant statutory regulations.
- Do not modify this appliance.
- In all cases the installation of this appliance shall meet the requirements as set out in AS/NZS5601.1-2013.

- NOTE: A slight smell may be apparent for the first few hours of use. This is due to the heat resistant paint curing. It is recommended to open windows in the room for the first lighting of the fire. In some instances a slight discolouration may occur inside the firebox. This is a normal condition and is not covered by warranty.

IMPORTANT SAFETY NOTICE

- DO NOT PLACE ARTICLES ON OR AGAINST THIS APPLIANCE.
- DO NOT USE OR STORE FLAMMABLE MATERIAL NEAR THE APPLIANCE.
- DO NOT SPRAY AEROSOLS IN THE VICINITY OF THIS APPLIANCE WHILST IT IS IN OPERATION.
- CARE MUST BE TAKEN TO ENSURE THAT ANY RETURN AIR REGISTER OR EXHAUST SYSTEM DOES NOT ADVERSLEY AFFECT THE OPERATION OF THE APPLIANCE OR DRAUGHT OF CHIMNEY OR FLUE.

SERVICING

It is recommended you service your gas fire every 2 years as a minimum.

CORD REPLACEMENT

Electrical cord replacement must be undertaken by qualified and trained personnel only.

- APPLIANCE IS DESIGNED TO OPERATE WITH LUMINOUS FLAMES.
MAY EXHIBIT SLIGHT CARBON DEPOSIT.

CONTENTS

| | |
|--------------------------------------|----|
| Contents | 4 |
| Dataplate | 5 |
| Dimensions | 5 |
| Installation instructions | 6 |
| Commissioning procedure | 36 |
| Media Installation | 37 |
| Operation - User Instructions | 41 |
| Flue Termination (Cowls) | 42 |
| Remote Control Operating Guide | 43 |
| Troubleshooting | 48 |
| Wiring Diagram | 49 |
| Conversion details | 50 |
| Parts List | 60 |
| Real Flame contact information | 64 |

DATA PLATE (Affixed to the base of the unit for reference to gas pressure & consumption)

| MODEL | ELEMENT 1200 | | |
|-------------|---------------|----------------------------|----------------|
| GAS TYPE | INJECTOR SIZE | TPP | N.G.C. (Mj/hr) |
| Natural Gas | 3 X 2.25mm | 0.85kPa High / 0.55kPa Low | 37 High/29 Low |
| LPG | 3 X 0.95mm | 2.50kPa High / 1.70kPa Low | 33 High/27 Low |
| ULPG | 3 X 0.95mm | 2.50kPa High / 1.70kPa Low | 33 High/27 Low |

DIMENSIONS

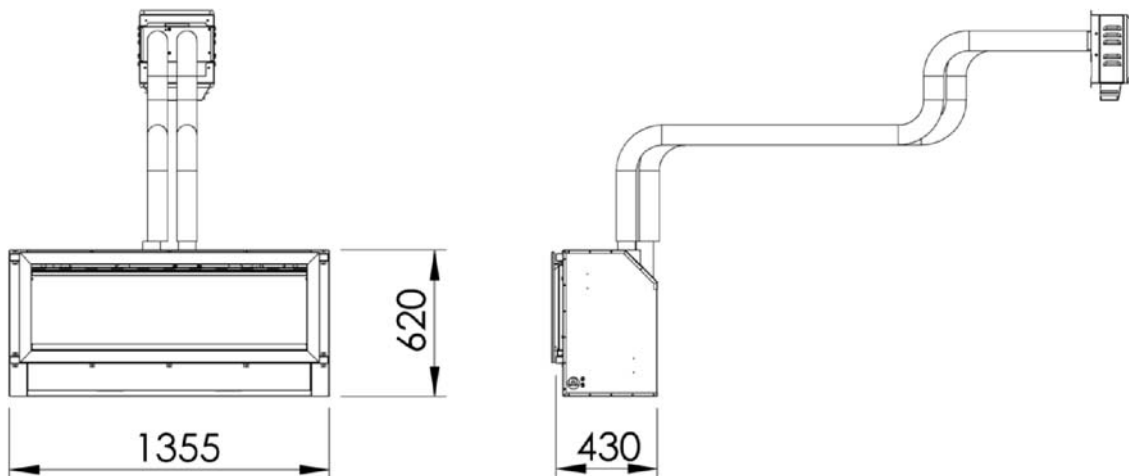

INSTALLATION INSTRUCTIONS

LOCATION

Select a location where the fire can be supervised during operation.

An electrical isolation switch must be fitted at the appliance or on an adjacent wall to allow for emergency shutdown and maintenance.

Installation must meet Australian gas code AS/NZS5601.1-2013.

INSTALLATION CLEARANCES – Clearances from combustible materials

| | |
|------------|------|
| Floor | 0mm |
| Sides | 25mm |
| Top | 25mm |
| Flue outer | 10mm |
| Front | 25mm |
| Back | 25mm |

INSTALLATION CODES

Note appliance gas type – Natural gas, LPG or ULPG. Should the appliance be the incorrect gas type, please contact the supplier.

Installers – Please ensure the installation and instruction manuals supplied with this appliance are supplied to the customer and the customer is trained on how to operate the appliance correctly.

Do not modify the appliance.

Do not exceed maximum rated pressures.

Appliance must be installed with gas installation code (AS/NZS5601.1-2013) and applicable electrical installation code (AS3000).

Test for gas leaks prior to operating appliance.

Check gas pressures and adjust if incorrect.

FLUE CONFIGURATIONS

For flue configurations 3m or less run an aluminium flexible flue for both the inlet and outlet.

Where lengths greater than 3m are required the inlet is run completely in aluminium flexible flue, the first 3m of the outlet flue is run in flexible aluminium flue, then a poly flue system is used that requires drainage points to waste for condensation removal.

Flue runs 3m or less (75mm diameter Aluminium flexi flue)

Maximum flue runs 3m total length including 3 x 90° bends

Appliance is supplied with a 3m flexible flue run.

Flue can be cut to length as required.

Recommended bend radius 150mm or larger.

Maximum of 3 bends.

Bends must not form a P Trap.

Flue must be clipped to support.

U style flue runs must not be installed

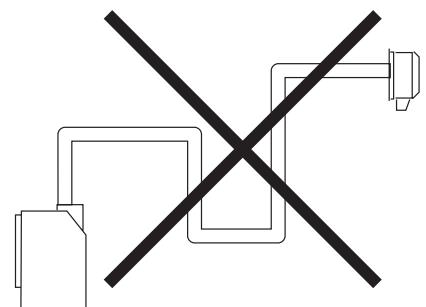

FLUE SPECIFICATIONS

75mm internal diameter twin walled aluminium flexible flue, supplied in 3m lengths. Flue external diameter approx. 83mm.

INSTALLATION INSTRUCTIONS (continued)

BALANCED FLUE TERMINATION LOCATION

This section is used to determine where your Balanced Flue termination will be located.

- Flue terminations shall not be recessed in walls or sidings.
- **EXTREMELY IMPORTANT:** In heavy snow areas take extra care to prevent blocking flue termination with snow removal equipment.
- Flue gases exiting flue terminals are very hot and must not be restricted to assure fireplace combustion is not affected.
- Do not place, build any obstruction, plant any bushes or for any reason attempt to conceal the flue termination. To do so will affect the operation of the fireplace and may be hazardous.
- This unit must always vent directly to outdoors.

SETUP WITH EXTERNAL WALL MOUNTED FAN MODULE

Maximum 3m flue length - total 3 bends

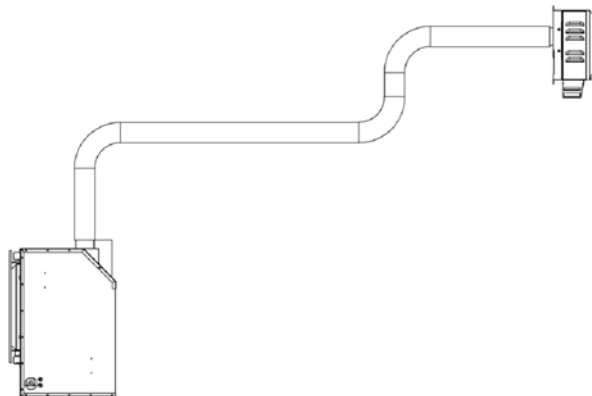

Wall mounted fan module

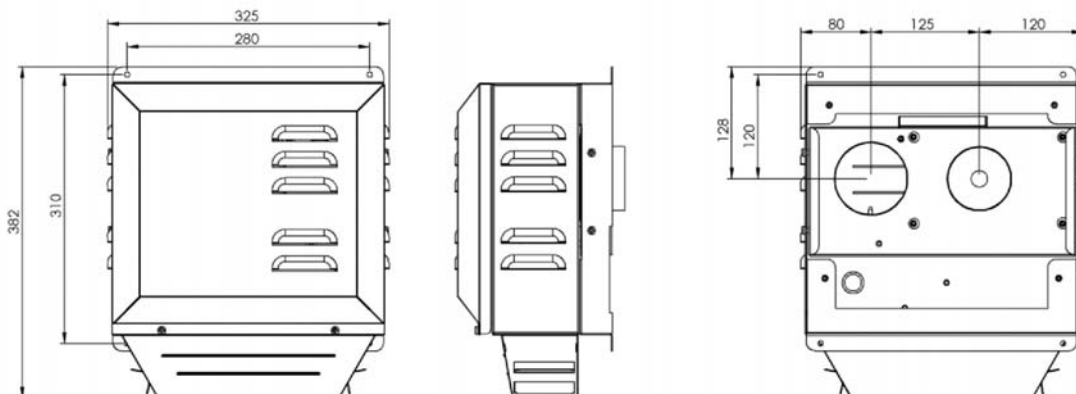

INSTALLATION INSTRUCTIONS (continued)

1. Wall mounted fan module – terminal must be installed with clearances as specified by AS5601.1 Clause 6.9.3
2. Run exhaust flue and air intake flue as required – Maximum run 3m. Flues can be run next to each other. Maintain clearances to combustibles.
3. Connection to appliance



Cut tube to length where required.

Ensure ends are burr free and round, test fit flue will slide over connection.



Recommended Silicon – Non-acetic, neutral cure 150°C or higher temperature rated.

Bostik RTV 926 or similar.

Apply an 8mm thick silicon bead fully around heater connection approx. 10mm from the top.



Apply an 8mm silicon bead fully around the inside of the flue end (heater connection end)

Fit flue clamp over flue (loosely).

INSTALLATION INSTRUCTIONS (continued)



Slide flue onto connection spigot fully.

Tighten clamp fully.

Wipe excess silicon, visually check connection to ensure connection is fully sealed.

4. Repeat above with air intake flue pipe to heater connection.
5. Clip flues as required to provide adequate support.
6. Connection to wall mounted fan terminal



Remove cover from fan terminal

Remove main assembly from the rear wall mounting plate assembly.

Remove the 5 screws as shown. (Do not remove fan plate screws)

Lift off main fan terminal assembly.

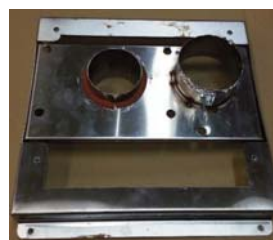

INSTALLATION INSTRUCTIONS (continued)



Remove wall mount plate from flue connection plate.



Cut flue exhaust tube (hot tube) to length (Approximately flush with wall exit). Connection plate will sit against wall.

Cut Air intake flue 70mm longer.

Ensure ends are burr free and round, test fit flue will slide over connection.

Apply an 8mm thick silicon bead fully around flue connection plate spigot approx. 10mm from the top.



Apply an 8mm silicon bead fully around the inside of the flue end (heater connection end)

Fit flue clamp over flue (loosely).



Slide flue onto connection spigot fully.

Tighten clamp fully.

Wipe excess silicon, visually check connection to ensure connection is fully sealed.

INSTALLATION INSTRUCTIONS (continued)



Feed air intake flue pipe through location spigot and fit retaining screw.

Push connection plate into approximate position.



Locate wall mounting bracket into position and affix to wall.



Assemble spigot connection plate assembly to wall mounting bracket. (4 screws)

INSTALLATION INSTRUCTIONS (continued)



Feed power cable through bottom area of bracket.



Assemble main body assembly onto wall mounting bracket, feed power cable through grommet hole prior to fitting. (refit 5 screws as shown and tighten) Main body assembly must sit flush up against the mounting bracket and seal.



INSTALLATION INSTRUCTIONS (continued)



Connect power cable connector.
Fit cable clamp to cable.



Fit front cover.

INSTALLATION INSTRUCTIONS (continued)

SETUP WITH INTERNAL FAN MODULE WITH WALL TERMINATION – APPLIANCE MOUNTED

Maximum 3m flue length – total 3 bends

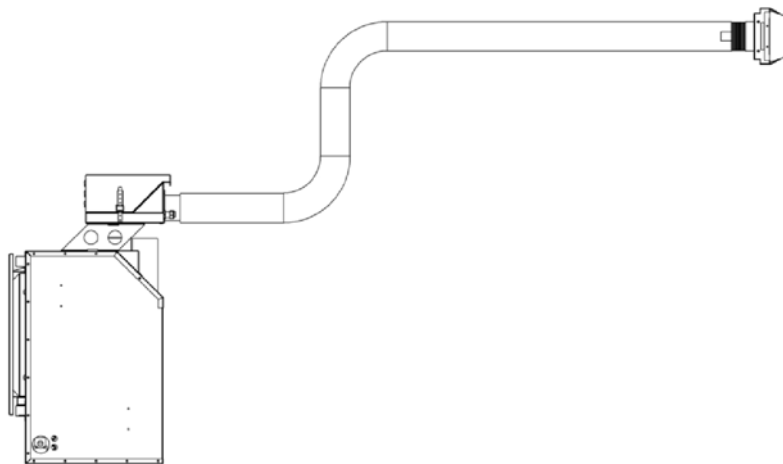

Wall termination

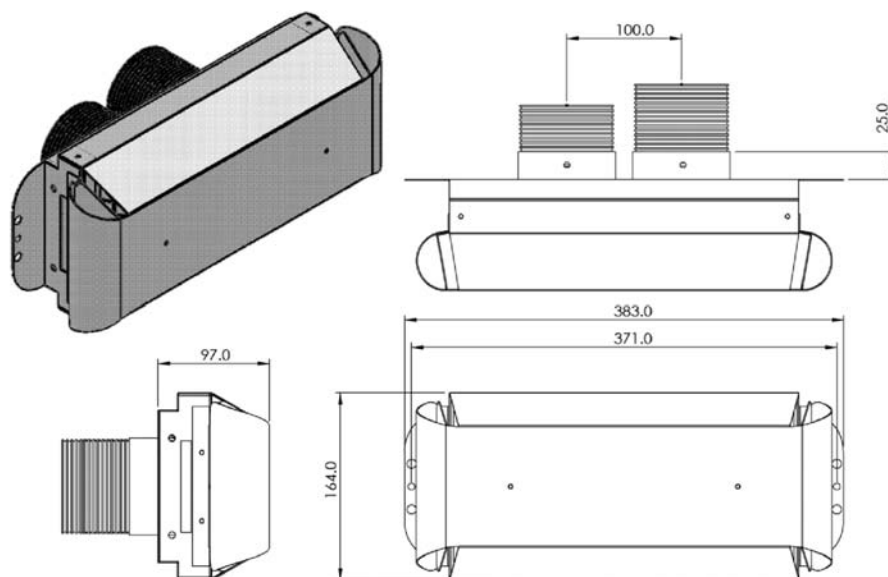

1. Wall terminal must be installed with clearances as specified by AS5601.1 Clause 6.9.3
2. Run exhaust flue and air intake flue as required – Maximum run 3m. Flues can be run next to each other. Maintain clearances to combustibles.
3. Connection to appliance

INSTALLATION INSTRUCTIONS (continued)



Check 65mm flue piece for correct shape and fitment onto appliance spigot.

Ensure ends are burr free and round, test fit flue will slide over connection.

Recommended Silicon – Non-acetic, neutral cure 150degc or higher temperature rated.
Bostik RTV 926 or similar.

Apply an 8mm thick silicon bead fully around heater connection approx. 10mm from the top.

Apply an 8mm thick silicon bead fully around the lower fan connection spigot approx. 10mm from the end.



Apply an 8mm silicon bead fully around the inside of the flue end, both ends.



Turn fan assembly upside down and slide 65mm flue section fully onto spigot.

Fit flue clamp and tighten clamp fully.

Wipe excess silicon, visually check connection to ensure connection is fully sealed.

INSTALLATION INSTRUCTIONS (continued)



Fit 2nd flue clamp loosely onto the 65mm section of flue.

Lift fan assembly into appliance and locate onto flue connection. Insert fully. Locate fan in the required direction. Screw fan assembly down onto the appliance. (Screws prefitted into holes are located on the appliance for direct out back connection and 90° to right connection.)

(Note 90° left connection is not available and must be done using the 90° right connection fan location and placing a bend in the flue to head in the LH direction.)

Locate 2nd clamp onto lower connection and tighten clamp fully.

Wipe excess silicon, visually check connection to ensure connection is fully sealed.

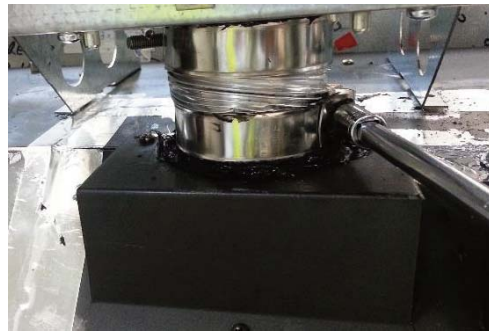

3/ Fit hot exhaust flue pipe from outlet termination to fan outlet connection.

Cut tube to length where required.

Ensure ends are burr free and round, test fit flue will slide over connection.



INSTALLATION INSTRUCTIONS (continued)



Apply an 8mm thick silicon bead fully around heater connection approx. 10mm from the top.
Apply an 8mm silicon bead fully around the inside of the flue end (heater connection end)
Fit flue clamp over flue (loosely).



Slide flue onto connection spigot fully.
Tighten clamp fully.
Wipe excess silicon, visually check connection to ensure connection is fully sealed.



Connect power cable to fan module



4. Fit air intake flue pipe to heater connection.
Cut tube to length where required.
Ensure ends are burr free and round, test fit flue will slide over connection.

INSTALLATION INSTRUCTIONS (continued)



Apply an 8mm thick silicon bead fully around heater connection approx. 10mm from the top.



Apply an 8mm silicon bead fully around the inside of the flue end (heater connection end).
Fit flue clamp over flue (loosely).



Slide flue onto connection spigot fully.
Tighten clamp fully.
Wipe excess silicon, visually check connection to ensure connection is fully sealed.



5. Clip flues as required to provide adequate support.

INSTALLATION INSTRUCTIONS (continued)

6. Connection to wall terminal

LOOSE FIT CONNECTIONS (Wall termination connections)

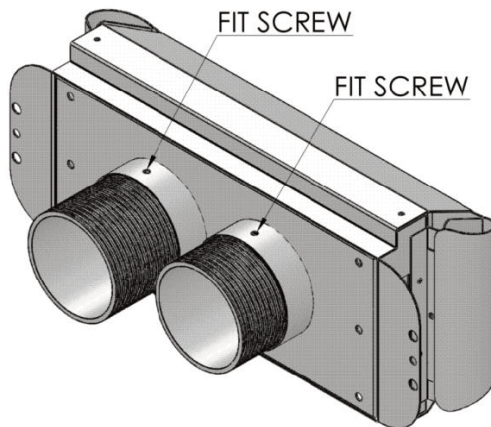

Locate terminal on wall and predrill mounting holes where required.



Cut flue exhaust tube (hot tube) to length (Flue must extend a minimum of 50mm past the exit face of wall.) It is recommended that the tubes are cut slightly longer and pushed back into wall upon fixing of wall terminal. Allow flue movement between terminal and last flue hanging clip.

Cut Air intake as per flue exhaust.

Ensure ends are burr free and round, test fit flue will slide inside both the hot exhaust connection and air intake connection.

INSTALLATION INSTRUCTIONS (continued)



Feed air hot exhaust flue into connection, ensure inserted 50mm. Fit retaining screw from below.



Feed air intake flue into connection, ensure inserted 50mm. Fit retaining screw from below.

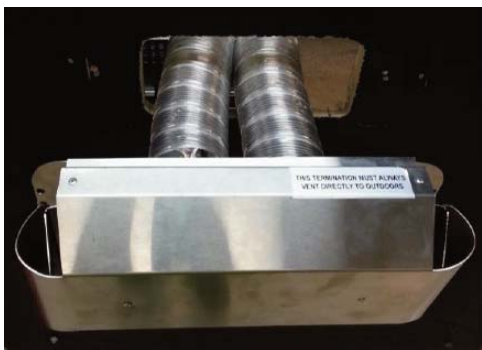

Push terminal into approximate position and affix onto wall.



INSTALLATION INSTRUCTIONS (continued)

SETUP WITH INTERNAL FAN MODULE WITH WALL TERMINATION - MID FLUE MOUNTED

Maximum 3m flue length - total 3 bends (Intake flue- 4 bends allowed)

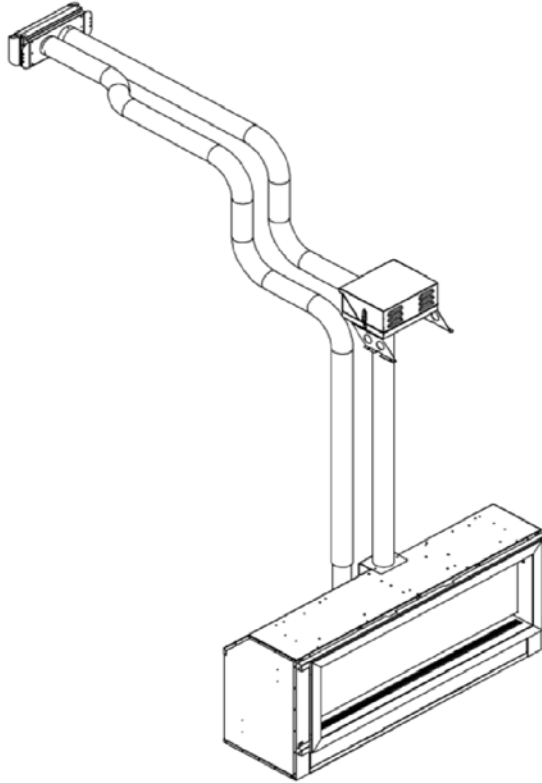

Wall termination - same as appliance mounted wall termination

1. Wall terminal must be installed with clearances as specified by AS5601.1 Clause 6.9.3
2. Run exhaust flue and air intake flue as required – Maximum total run 3m per flue. Flues can be run next to each other. Maintain clearances to combustibles.
3. Mount fan controller in the required location. (Access to the fan module is required for service an access panel or ceiling access must be provided.)

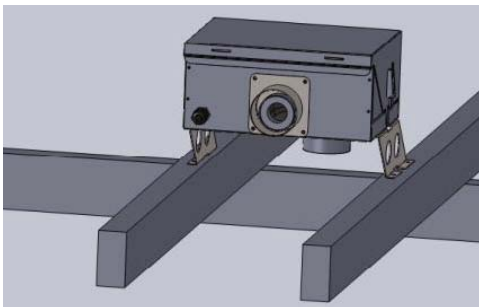

4. Connection to fan module to appliance
Run flue from appliance to bottom entry on fan module.
Support flue with brackets as required

INSTALLATION INSTRUCTIONS (continued)



Cut flue to length to suit connection.
Ensure ends are burr free and round, test fit flue will fit over connection.



Apply an 8mm thick silicon bead fully around heater connection approx. 10mm from the top.



Apply an 8mm silicon bead fully around the inside of the flue end (heater connection end)
Fit flue clamp over flue (loosely).



Slide flue onto connection spigot fully.
Tighten clamp fully.
Wipe excess silicon, visually check connection to ensure connection is fully sealed.

INSTALLATION INSTRUCTIONS (continued)



Repeat for connection to underside of fan module.



Repeat for Air intake flue connection.



5. Fan module outlet connection
Cut tube to length where required.
Ensure ends are burr free and round, test fit flue will slide over connection.



- Apply an 8mm thick silicon bead fully around heater connection approx. 10mm from the top.
Apply an 8mm silicon bead fully around the inside of the flue end (heater connection end)
Fit flue clamp over flue (loosely).

INSTALLATION INSTRUCTIONS (continued)

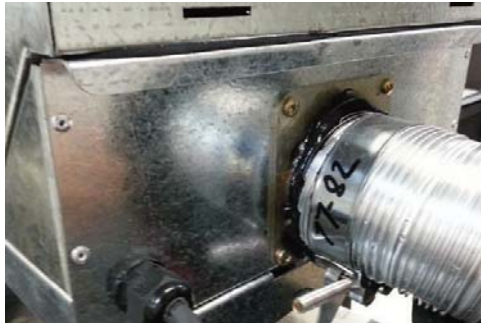

- Slide flue onto connection spigot fully.
- Tighten clamp fully.
- Wipe excess silicon, visually check connection to ensure connection is fully sealed.



- 6. Connect power lead to fan module. Ensure lead is clipped to support where required.
- Do not use connection to support lead.

- 7. Connection to wall terminal

LOOSE FIT CONNECTIONS (Wall termination connections)

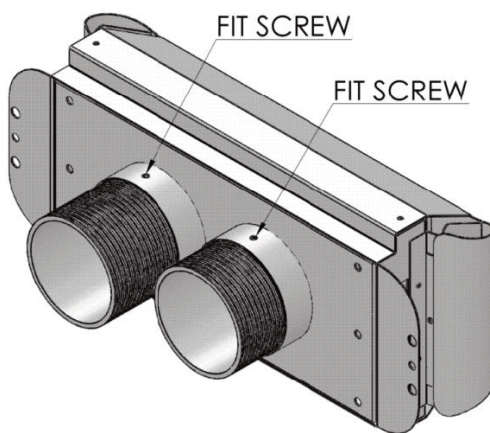

INSTALLATION INSTRUCTIONS (continued)



Locate terminal on wall and predrill mounting holes where required.

Cut flue exhaust tube (hot tube) to length (Flue must extend a minimum of 50mm past the exit face of wall.) It is recommended that the tubes are cut slightly longer and pushed back into wall upon fixing of wall terminal. Allow flue movement between terminal and last flue hanging clip.

Cut Air intake as per flue exhaust.

Ensure ends are burr free and round, test fit flue will slide inside both the hot exhaust connection and air intake connection.



Feed air hot exhaust flue into connection, ensure inserted 50mm. Fit retaining screw from below.



Feed air intake flue into connection, ensure inserted 50mm. Fit retaining screw from below.

INSTALLATION INSTRUCTIONS (continued)

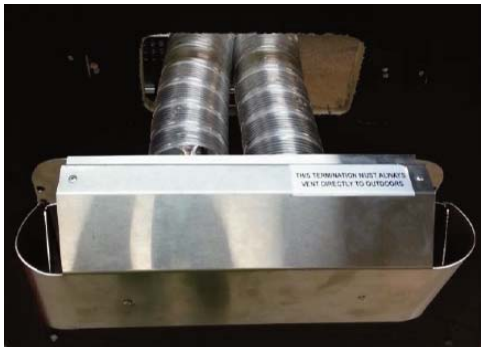

Push terminal into approximate position and affix onto wall.

SETUP WITH INTERNAL FAN MODULE WITH ROOFTOP TERMINATION – MID FLUE MOUNTED

Maximum 3m flue length – total 3 bends (Intake flue- 4 bends allowed)

Note – fan module can be appliance mounted or mid mounted when finishing with the rooftop termination.

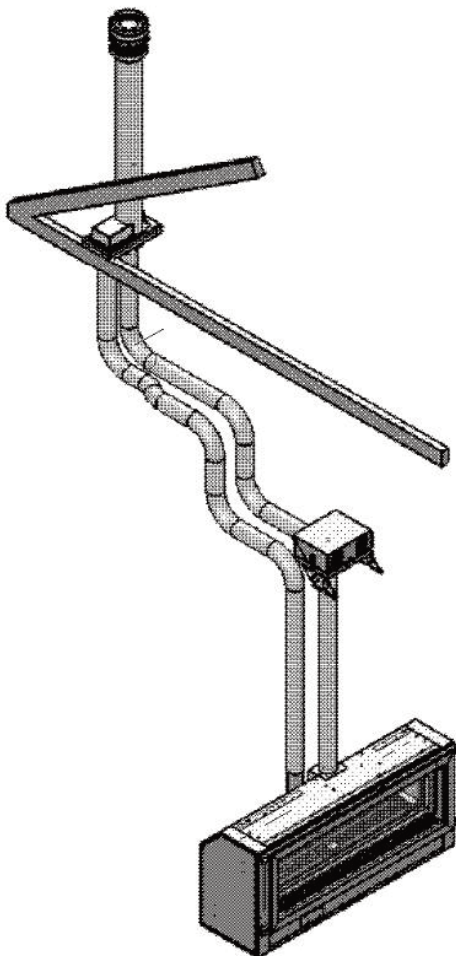

INSTALLATION INSTRUCTIONS (continued)

1. Rooftop termination must be installed with clearances as specified by AS5601.1
2. Run exhaust flue and air intake flue as required – Maximum total run 3m per flue. Flues can be run next to each other. Maintain clearances to combustibles.
3. Mount fan controller in the required location. (Access to the fan module is required for service an access panel or ceiling access must be provided.) Fan module can also be directly mounted to appliance – refer direct mounted instructions.
4. Exhaust flues are insulated in this flue configuration. The entire length (up to 3m) of exhaust flue only is to be insulated with the factory supplied insulation. The air intake flue does not need to be insulated.

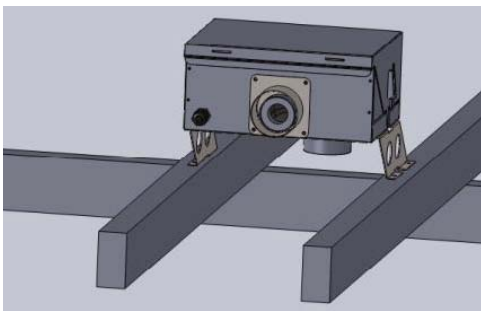

5. Connection to fan module to appliance



Preinsulate exhaust flue, the required length.
(Approximate 25m each end uninsulated)



Run flue from appliance to bottom entry on fan module.

Support flue with brackets as required

Cut flue to length to suit connection.

Ensure ends are burr free and round, test fit flue will fit over connection.

INSTALLATION INSTRUCTIONS (continued)



Apply an 8mm thick silicon bead fully around heater connection approx. 10mm from the top.



Apply an 8mm silicon bead fully around the inside of the flue end (heater connection end)
Fit flue clamp over flue (loosely).



Slide flue onto connection spigot fully.
Tighten clamp fully.
Wipe excess silicon, visually check connection to ensure connection is fully sealed.

INSTALLATION INSTRUCTIONS (continued)



Repeat for connection to underside of fan module.



Repeat for Air intake flue connection.



6. Fan module outlet connection

Cut tube to length where required.

Ensure ends are burr free and round, test fit flue will slide over connection.



Apply an 8mm thick silicon bead fully around heater connection approx. 10mm from the top.

Apply an 8mm silicon bead fully around the inside of the flue end (heater connection end)

Fit flue clamp over flue (loosely).

INSTALLATION INSTRUCTIONS (continued)



Slide flue onto connection spigot fully.

Tighten clamp fully.

Wipe excess silicon, visually check connection to ensure connection is fully sealed.



7. Connect power lead to fan module. Ensure lead is clipped to support where required.

Do not use connection to support lead.

8. Connection to rooftop terminal

Prepare roof penetration.

Remove cowl from termination if fitted.

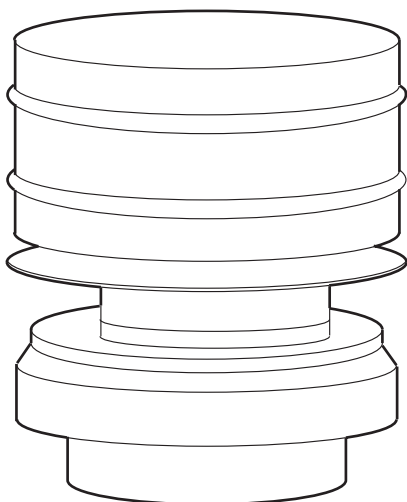

INSTALLATION INSTRUCTIONS (continued)

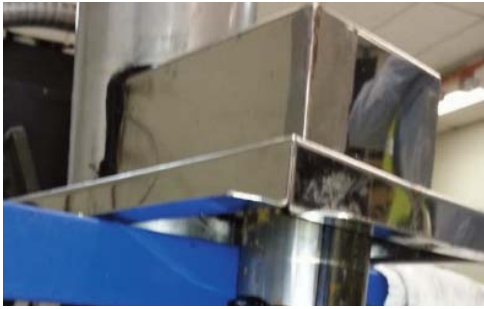

Cut rooftop penetration to length if required.
Install into roof penetration.
Install supports for base of penetration kit



Connect hot exhaust flue and air intake flue as per below.
Apply an 8mm silicon bead fully around the inside of the flue end.
Fit flue clamp over flue (loosely).



Slide flue onto connection spigot fully.
Tighten clamp fully.
Wipe excess silicon, visually check connection to ensure connection is fully sealed.

INSTALLATION INSTRUCTIONS (continued)



Fit roof sealing method. (Decktite or similar)

Fit rooftop cowl. Screw or rivet in 3 places to hold into place.

Ensure flue is supported and clipped where required.

TIMBER FRAME INSTALLATION

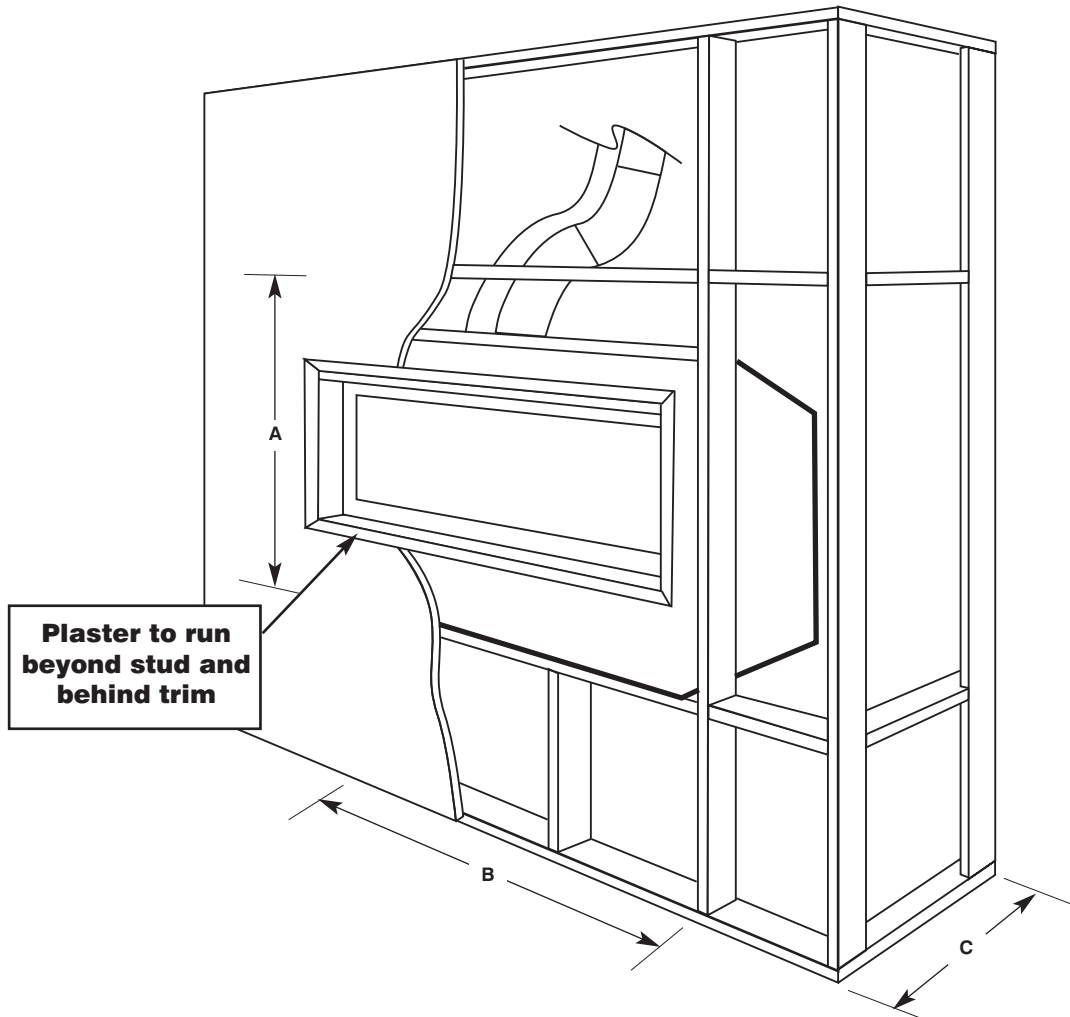

Frameout Dimensions (in mm)

| A | B | C |
|-----|------|-----|
| 660 | 1420 | 460 |

TIMBER FRAME INSTALLATION (continued)

APPLIANCE MOUNTED FLUE FAN (FITTED WITH FAN ACCESS TRIM)

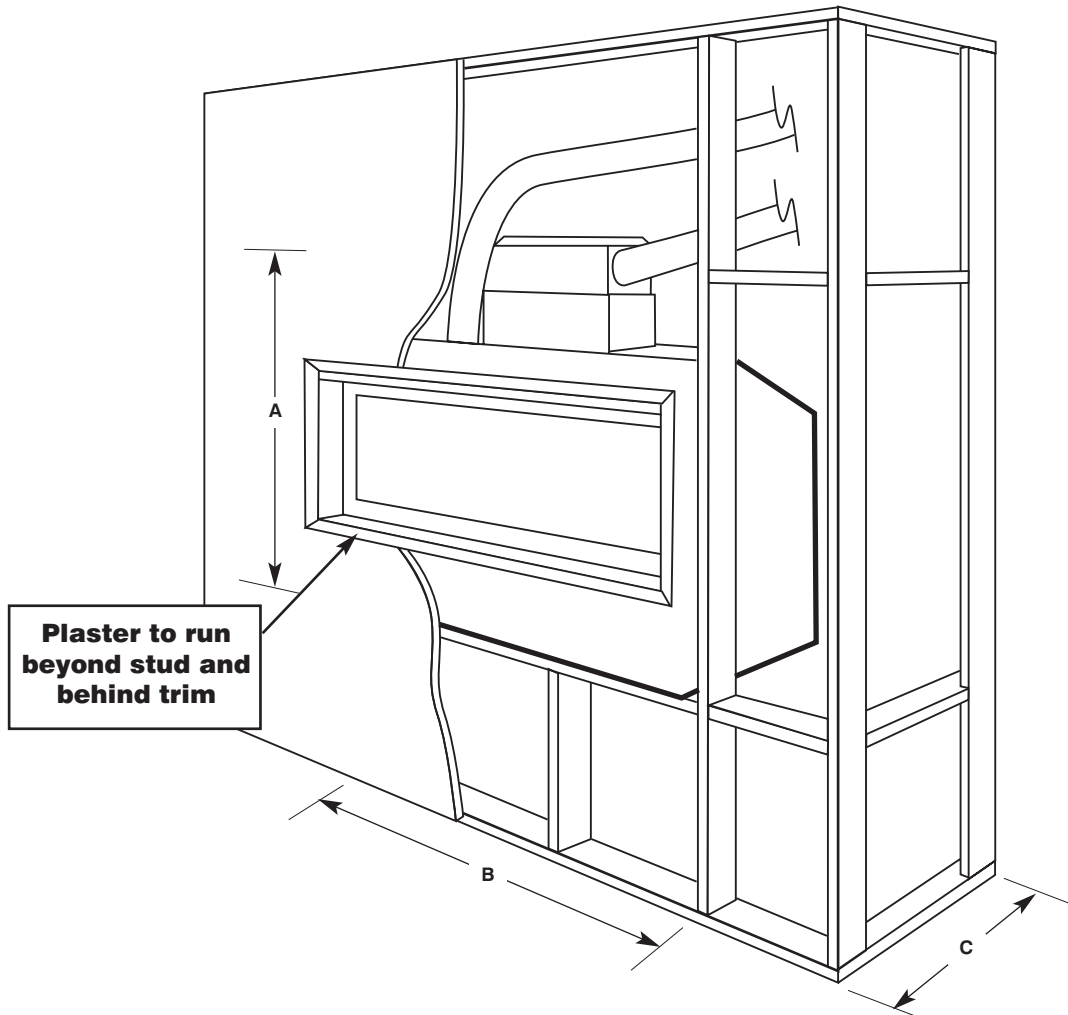

Frameout Dimensions (in mm)

| A | B | C |
|-----|------|-----|
| 880 | 1420 | 460 |

TIMBER FRAME INSTALLATION

18mm Trim

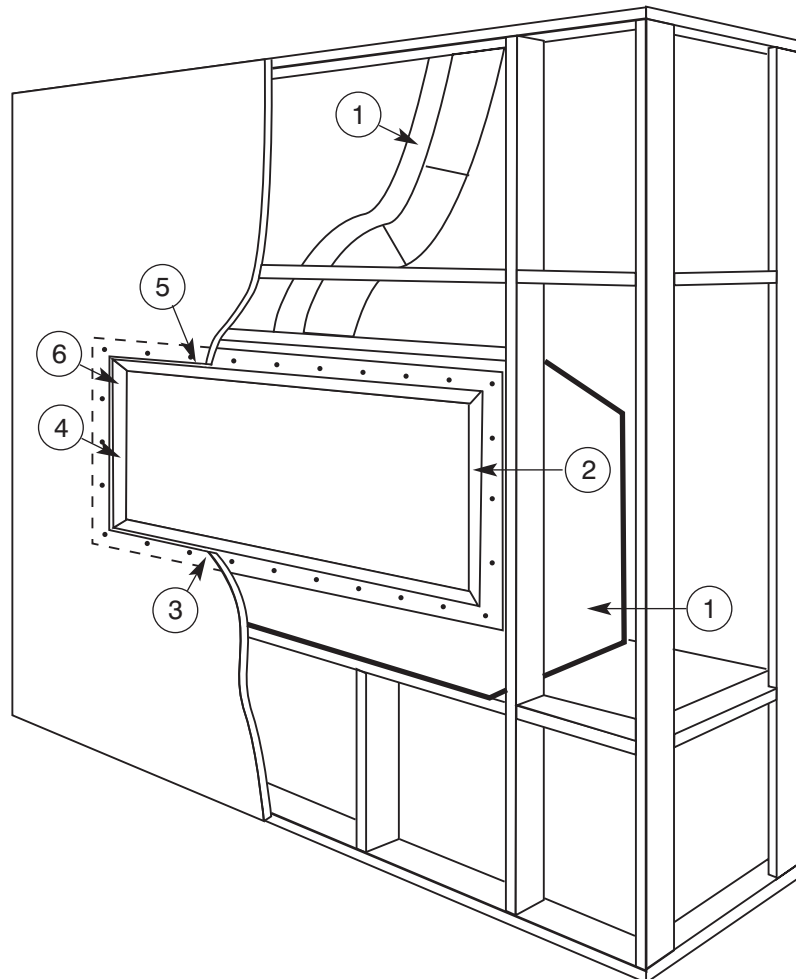

1. Install Element 1200 onto base and connect flue, gas and power.
2. Fit 18mm trim frame.
3. Locate 4 sided flange kit.
4. Remove 18mm frame.
5. Clad wall to flange kit and finish.
6. Refit 18mm trim frame.

COMMISSIONING PROCEDURE

50mm trim

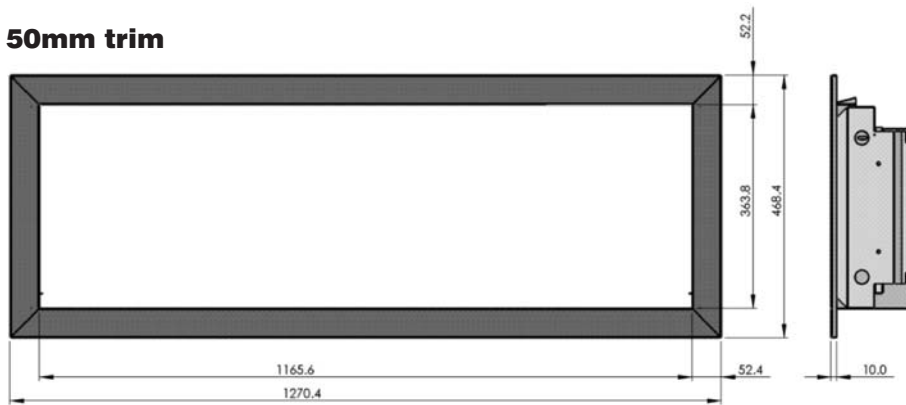

18mm trim flange kit

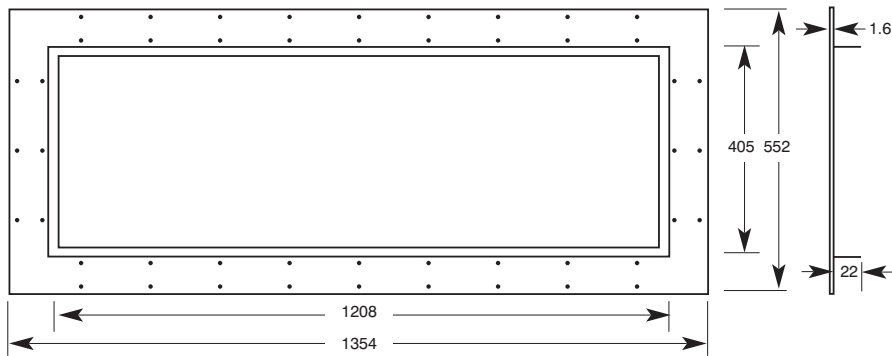

18mm low profile trim

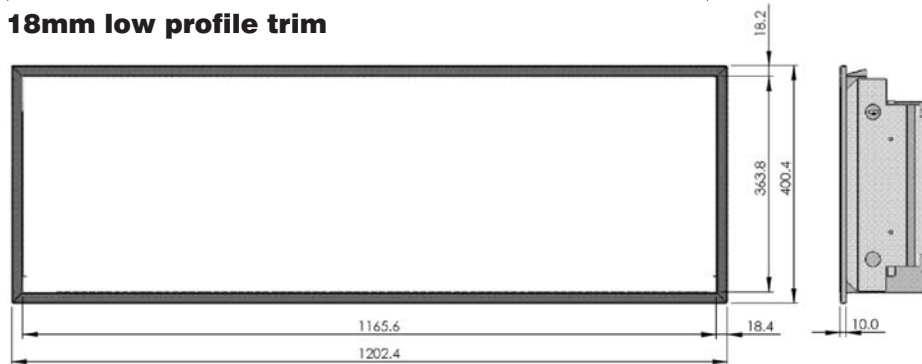

BB trim (provides access to flue motor)

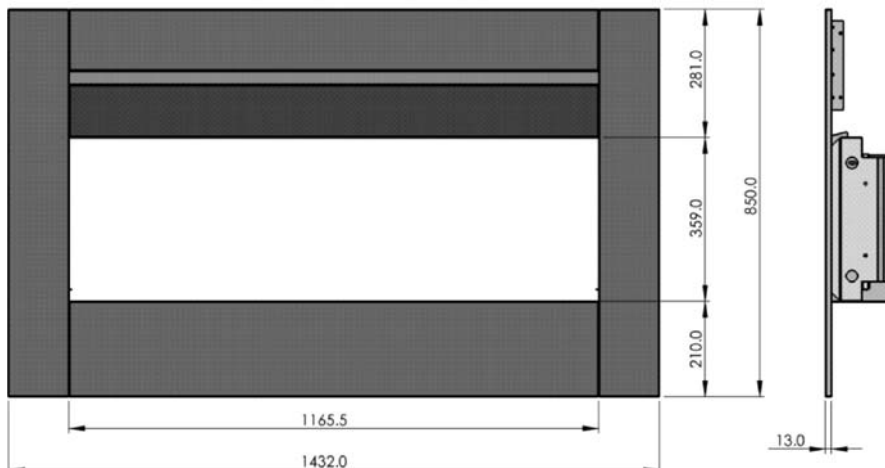

COMMISSIONING PROCEDURE (continued)

Once the fire is installed:

- Install media.
- Check for gas leaks.
- Connect powerflue module loom to fan control unit.
- Carry out the lighting procedure.
- Check burner pressures and adjust as per Dataplate.
- Fit access cover and trim.
- Handover instructions to owner.
- Instruct owner on how to operate the fireplace safely.
- Instruct owner how to isolate appliance in an emergency.

MEDIA INSTALLATION

Driftwood

- Lay driftwood media in a random arrangement along the entire length of the burner.
- Avoid smothering the burner channel.
- Ensure media is not heaped in areas, spread evenly along.
- Do not add extra media, or combine media types.
- Only the approved supplied media is to be used.
- Refer to Real Flame for technical advice regarding media.
- Do not cover pilot area.
- Do not overfill with media above the pilot cover level.
- Ensure the pilot flame is not impinged by media and can cross light the main burner.
- Do not use any other media than as supplied and recommended by the manufacturer.
- Use of other media may result in explosive media which may cause injury or damage.

Typical setup



IMPORTANT - Do not cover or block pilot area.

MEDIA INSTALLATION (continued)

Coals only

- Lay coal media in a random arrangement along the entire length of the burner.
- Avoid smothering the burner channel. Apply coals either side of the flame channel.
- No more than 4 coals should cover the main flame channel.
- Ensure media is not heaped in areas, spread evenly along.
- Do not add extra media, or combine media types.
- Only the approved supplied media is to be used.
- Do not cover pilot area.
- Do not overfill with media above the pilot cover level.
- Ensure the pilot flame is not impinged by media and can cross light the main burner.
- Do not use any other media than as supplied and recommended by the manufacturer.
- Use of other media may result in explosive media which may cause injury or damage.

Typical setup



MEDIA INSTALLATION (continued)

Logs and Coals

- Lay coal media in a random arrangement along the entire length of the burner.
- Avoid smothering the burner channel. Apply coals either side of the flame channel.
- Ensure media is not heaped in areas, spread evenly along.
- Randomly place logs between and on top of the coal media in an evenly spread out pattern.
- Do not add extra media, or combine media types.
- Only the approved supplied media is to be used.
- Do not cover pilot area.
- Do not overfill with media above the pilot cover level.
- Ensure the pilot flame is not impinged by media and can cross light the main burner.
- Do not use any other media than as supplied and recommended by the manufacturer.
- Use of other media may result in explosive media which may cause injury or damage.

Typical setup



MEDIA INSTALLATION (continued)

Pebbles

- Lay large pebble media in a random arrangement along the entire length of the burner.
- Avoid smothering the burner channel.
- Fill in voids with medium size pebbles.
- Fill in remaining voids with small pebbles.
- Pebbles should appear as a random mix and not be stacked more than 2 high in a few spots.
- Ensure media is not heaped in areas, spread evenly along.
- Do not add extra media, or combine media types.
- Only the approved supplied media is to be used.
- Refer to Real Flame for technical advice regarding media.
- Do not cover pilot area.
- Do not overfill with media above the pilot cover level.
- Ensure the pilot flame is not impinged by media and can cross light the main burner.
- Do not use any other media than as supplied and recommended by the manufacturer.
- Use of other media may result in explosive media which may cause injury or damage.

Typical setup



OPERATION – USER INSTRUCTIONS

- Do not operate if you smell gas. Turn appliance off, extinguish any open flame. Contact your installer or a licensed gasfitter.
- Do not use if any part of this appliance has been submerged in water. Contact your installer or a qualified service technician.
- Solid fuels must not be burnt in the fire. Leaves, sticks, wood, paper food or material must be kept away from the fire.
- Appliance operates with luminous flames, carbon deposits may occur during operation.

ELEMENT 1200 FLUE TERMINATION (COWLS)

Balanced Flue

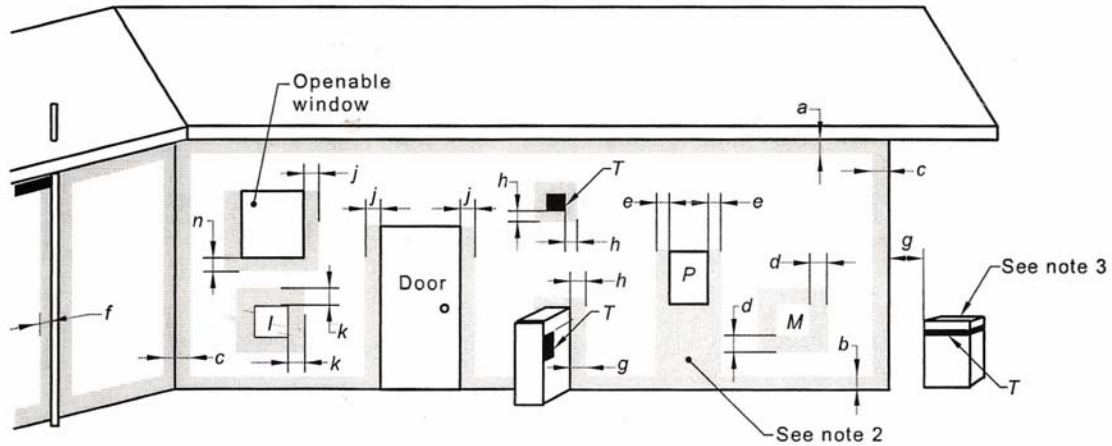

LEGEND:

- T = Flue terminal
- I = Mechanical air inlet
- M = Gas meter
- P = Electricity meter or fuse box
- Shading indicates prohibited areas for flue terminals

| Ref. | Item | Minimum clearances (mm) | |
|------|---|-------------------------|--------------|
| | | Natural draft | Fan assisted |
| a | Below eaves, balconies and other projections: | | |
| | • Appliances up to 50 MJ/h input | 300 | 200 |
| | • Appliances over 50 MJ/h input | 500 | 300 |
| b | From the ground, above a balcony or other surface † | 300 | 300 |
| c | From a return wall or external corner † | 500 | 300 |
| d | From a gas meter (M) (see 4.7.11 for vent terminal location of regulator) | 1000 | 1000 |
| e | From an electricity meter or fuse box (P) | 500 | 500 |
| f | From a drain pipe or soil pipe | 150 | 75 |
| g | Horizontally from any building structure † or obstruction facing a terminal | 500 | 500 |
| h | From any other flue terminal, cowl, or combustion air intake † | 500 | 300 |
| j | Horizontally from an openable window, door, non-mechanical air inlet, or any other opening into a building with the exception of sub-floor ventilation: | | |
| | • Appliances up to 150 MJ/h input | 500 | 300 |
| | • Appliances over 150 MJ/h input up to 200 MJ/h input | 1500 | 300 |
| | • Appliances over 200 MJ/h input up to 250 MJ/h input † | 1500 | 500 |
| | • Appliances over 250 MJ/h input † | 1500 | 1500 |
| | • All fan-assisted flue appliances, in the direction of discharge | - | 1500 |
| k | From a mechanical air inlet, including a spa blower | 1500 | 1000 |
| n | Vertically below an openable window, non-mechanical air inlet, or any other opening into a building with the exception of sub-floor ventilation: | | |
| | • Space heaters up to 50 MJ/h input | 150 | 150 |
| | • Other appliances up to 50 MJ/h input | 500 | 500 |
| | • Appliances over 50 MJ/h input and up to 150 MJ/h input | 1000 | 1000 |
| | • Appliances over 150 MJ/h input | 1500 | 1500 |

† Unless appliance is certified for closer installation

NOTES:

- 1 All distances are measured to the nearest part of the terminal.
- 2 Prohibited area below electricity meter or fuse box extends to ground level.
- 3 See Clause 5.13.6.6 for restrictions on a flue terminal under a covered area.
- 4 See Appendix J, Figures J2(a) and J3(a), for clearances required from a flue terminal to an LP Gas cylinder. A flue terminal is considered to be a source of ignition.
- 5 For appliances not addressed above acceptance should be obtained from the technical regulator

REMOTE CONTROL OPERATING GUIDE



The Element 1200 is controlled completely by the use of the remote control; this remote can be used either as a manual operation or an auto operation.

- The remote thermostat uses radio frequency to transmit to the gas/fan controller.
- The remote thermostat has a LCD display
- The remote thermostat uses 2 off “AA” batteries which should last for 12 months. (Depending on quality of battery.) Batteries should be changed when smoke alarms are changed.
- The remote control and the controller are non-serviceable parts and if faulty should be returned to Real Flame Pty Ltd for replacement.

Locating the remote

The remote houses the thermostat that controls the heat output of the fire. When storing the remote either on its wall bracket or by placing it somewhere in the room where the fire is located, ensure there are no other heat sources that will affect the thermostats ability to accurately read the room temperature. For example, by placing the remote in direct sunlight or under a cushion, the fire may turn down or off before the room reaches the set temperature.

Factory Set Features

- When turned on the fire will always start on the low setting and remain on low for 3 minutes, it will then go to the high setting.
- The fan will automatically come on in the high mode after the fire has been operating for 3 minutes 20 seconds.
- When the fire shuts off on auto mode or is shut off in manual mode, the fan will continue to operate for 3 minutes in the “High” mode.
- The fire can be operated in either “Auto” mode or “Manual” mode.

Quick Start Guide

On/Off

Press and release the  button to turn the thermostat on and off.

Setting the day of the week and time

With the thermostat off, press and hold the ‘T’ button for 2 seconds or longer to initiate programming the time. Time, the hour setting and AM/PM will flash.

Setting the hour function

Press and release the ▲ or ▼ button to increase or decrease the hour setting by 1 hour.

Press ‘OK’ to accept.

Setting the minute function

Press and release, or press and hold the ▲ or ▼ button to increase or decrease the minute setting by 1 minute.

Press ‘OK’ to accept.

Setting the day of the week function

Press and release the ▲ or ▼ button to change the day of the week to the following or previous day. Press and hold the ▲ or ▼ button for 2 seconds or longer to increase or decrease the day of the week by 1 day every 0.5 seconds.

Press ‘OK’ to complete setting.

REMOTE CONTROL OPERATING GUIDE (continued)

Manual mode

Manual mode does not require that the time and day of the week are set.

Press the ▲ or ▼ button to increase or decrease the temperature desired.

Automatic mode

The automatic mode allows the temperature to be regulated according to a programmed level and time.

Manually overriding the set program

At any time, the temperature may be adjusted up or down. However, whenever the thermostat changes to a new time period, the temperature will be set automatically according to that period's setting.

Programming

Each day of the week can be programmed individually for 4 periods P1, P2, P3 and P4, making a total of 28 programmed periods.

Alternatively, a weekday program can be set, so the same program is used for Monday-Friday. Similarly, a weekend program can be set for Saturday-Sunday. The entire week can also have the same program.

Alternatively, a weekday or weekend program can be set with individual programs for the remaining days.

The suggested period settings for each day/s are:

- Period 1 - morning
- Period 2 - daytime
- Period 3 - evening
- Period 4 - night-time

To begin programming

With the thermostat off, press and hold the 'P' button for 2 seconds or longer to initiate programming. The LCD will display **PROG**, **Pd** and the time at which the thermostat is currently set. **MO** will flash.

Period 1 can now be set.

- *Setting the day of the week*

You must choose which day/s of the week you wish to program.

Press and release the ▲ or ▼ button to change the day of the week to the following or previous day. Press and hold the ▲ or ▼ button for 2 seconds or longer to increase or decrease the day of the week by 1 day every 0.5 seconds.

The order that you can scroll through the days is as follows:

MO → TU → WE → TH → FR → MO TU WE TH FR → SA → SU → SU SA → MO TU WE TH
FR SA SU

To accept the selected day/s of the week press 'OK'.

REMOTE CONTROL OPERATING GUIDE (continued)

Programming

- *Setting the period starting time*

The hour and AM/PM settings will now flash. To set the P1 starting time, press and release the ▲ or ▼ button to increase or decrease the hour setting. Press and hold the ▲ or ▼ button for 2 seconds or longer to increase or decrease the hour setting by 1 hour every 0.5 seconds.

Please ensure that AM/PM is set correctly.

Press 'OK' to accept.

The minute setting will now flash. Adjust the minute setting similarly, using ▲ or ▼ button

Press 'OK' to accept.

- *Setting the temperature*

The temperature setting will now flash. Press and release the ▲ or ▼ button to increase or decrease the temperature setting by 1 °C. Press and hold the ▲ or ▼ button for 2 seconds or longer to increase or decrease the temperature setting by 1°C every 0.5 seconds.

Press 'OK' to accept.

Period 1 is now set for the day/s of the week that you have chosen. The LCD will display **P2** to indicate that Period 2 can now be set for the same day/s of the week.

Repeat the programming process for periods 3 and 4.

After program 4 is set, press 'OK' and the program for the selected day/s will be set.

Repeat the programming process for any other periods/days that are required.

Restore factory default settings

With the thermostat off, press the following sequence of buttons: 'P', 'T', 'T' ▼.

Teaching RF thermostat ID code to control unit

CAUTION: The thermostat has already been programmed with a unique code. Do not attempt to teach the RF Thermostat ID code unless instructed by the manufacturer.

With the thermostat off, press the following sequence of buttons: 'P', 'T', 'T' ▲.

The LCD display will show 'CL' (Code Learn) for 2 seconds then return to the normal OFF state display. During this time a special code will be transmitted by the RF Thermostat to the Control Unit, causing the Control Unit to learn its ID.

WARNING

When the RF thermostat is in the "Auto" mode and the room temperature drops below the minimum temperature, the fire and fan will come on and operate until the room temperature is 3° above the minimum and then turn off, therefore:

- The minimum temperature should be set at a temperature that is not likely to cause the fire to continually turn on and off.
- If leaving the house for an extended period, the RF thermostat should be turned "OFF".
- As long as the RF thermostat is in the "Auto" mode and the temperature goes below the minimum set temperature, the fire will come on no matter what times are programmed into the thermostat.
- If you are unsure of the operation of the RF thermostat, please contact the manufacturer.

WIFI DEVICE CONTROL INSTRUCTIONS (Optional feature)

Wifi control is available as an option on the Element space heater where ordered at time of manufacture.

Wifi control offers temperature and a programable thermostat feature which can be use in conjunction with the supplied remote control or as the independent control.

Multiple devices can control the appliance. The appliance will operate based on its last received command.

Note 1 – Multiple devices may be connected to the appliance, only one appliance can be controlled by a device at a time.

Note 2 – The room air temperature sensing device is located at the appliance, accuracy of the temperature sensing may be effected by the room layout, appliance installation and nearby furniture.

APP Download

Goto Google store or ISTORE pending device

Setup

1. Turn of WIFI on device
2. Connect to appliance

Addresses - Millec_ID_AP_?????

Or RealFlame_ID_AP_?????

3. Goto the Real Flame Thermostat App on the device.

Press Manual or Auto mode

Manual mode offers on/off control, and operation using temperature control.

Auto mode is a 7 day programable thermostat, offering multiple temperature and switching times.

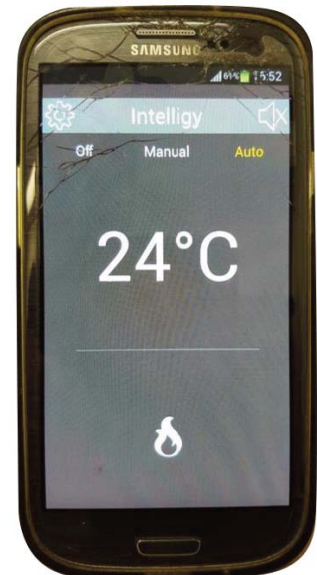

MANUAL MODE

Swipe left or right to raise or lower the temperature.

If the requested temperature is above the room sensed temperature the heater will operate.

The heater will continue to operate until the room temperature rises 3 degrees above the setpoint temperature on the device, once the temperature drops below the setpoint the fire will resume operation. The fire can also be stopped by pressing the off button.

To cease operation the OFF button on the device must be pressed. The heater will then remain in off mode until the remote or a device is operated to turn on the appliance.

NOTE- Manual mode incorporates an inbuilt safety feature, the appliance will turn off after 6hrs of operation if no further WIFI signal is received, The appliance will not restart until the remote or WIFI is reactivated.

WIFI DEVICE CONTROL INSTRUCTIONS (continued)

AUTO MODE

Auto mode offers a 7 day programmable thermostat when activated the fire will automatically operate on/off as per the time and temperature settings.

Auto mode will cease operation if the remote control or a device is used in manual model and auto mode is not reactivated.

Where a second device is programmed differently in auto mode the device will be asked to accept the old settings or override with the new settings. The selected settings will then be stored in the heater and device.

Programming AUTO mode

Press settings icon

Press "Auto modes >" screen bar

Press + icon to add times

Select required temperature

Select start time

Select days operation required

Press save



Once the program has been edited or completed arrow back, press OFF then press Auto to ensure the new program has been sent to the appliance. (Device must have Wifi on and be connected to appliance to send the program)

It is recommended that for each day a off time is added, other wise the heater remain on at the required temperature until the next switching time.

Press + icon to add times

Select required temperature (0degC recommended) – Fire will only operate if room temperature drops to 0DegC.

Select start time (Off time required)

Select days the off operation is required

Press save

This will ensure the heater will operate at the requested start time , run until the off time is reached where the appliance will remain off (unless temperature drops below the off temperature selected) until the next requested start time.

A guide program is as follows

Monday – Friday

7:00 am 21degC (Heater will operate to maintain 21degC)

9:00 am 17degC (Heater will operate as required to maintain 18degC)

5:00 pm 21degC (Heater will operate to maintain 21degC)

10:00pm 0degC (Heater will only operate if temperature drops below 0degC)

Saturday - Sunday

7:00 am 20degC (Heater will operate to maintain 20degC)

10:00pm 0degC (Heater will only operate if temperature drops below 0degC)

To exit programming screen press back arrow.

To edit a program line, press the screen on the required line to be changed.

To delete a program line, press the screen on the required line and hold. An option "Delete Auto timer "will appear. Select yes to delete the line.

TROUBLESHOOTING

| Problem | Possible Cause | Suggested Remedy |
|---|--|---|
| When the remote is activated nothing happens | The remote is not talking to the receiver. | Reprogramme the remote to the receiver (Refer Millennium manual in installation manual). |
| | The remote batteries are flat. | Replace the batteries. |
| The fire cuts off and won't relight | The over temp snap disc has been activated. | Allow the fire to cool down and then try to relight the fire. If the fire fails to relight, contact the manufacturer. |
| The fan will not come on | Possible caused by overheat or electrical fault. | Contact the manufacturer. |
| Flame appears to be low | Pressure not set. | All pressures are set in the factory at the time of manufacture, however the installing plumber must make sure the pressures are correct. |

**IF YOUR FIREPLACE STILL DOES NOT OPERATE CORRECTLY CONSULT YOUR DEALER.
ALL SERVICE AND REPAIRS SHOULD BE PERFORMED BY AN AUTHORISED AGENCY.
ALL SPARE PARTS AND OPTIONAL TRIM FINISHES ARE AVAILABLE FROM REAL FLAME PTY LTD.**

WIRING DIAGRAM

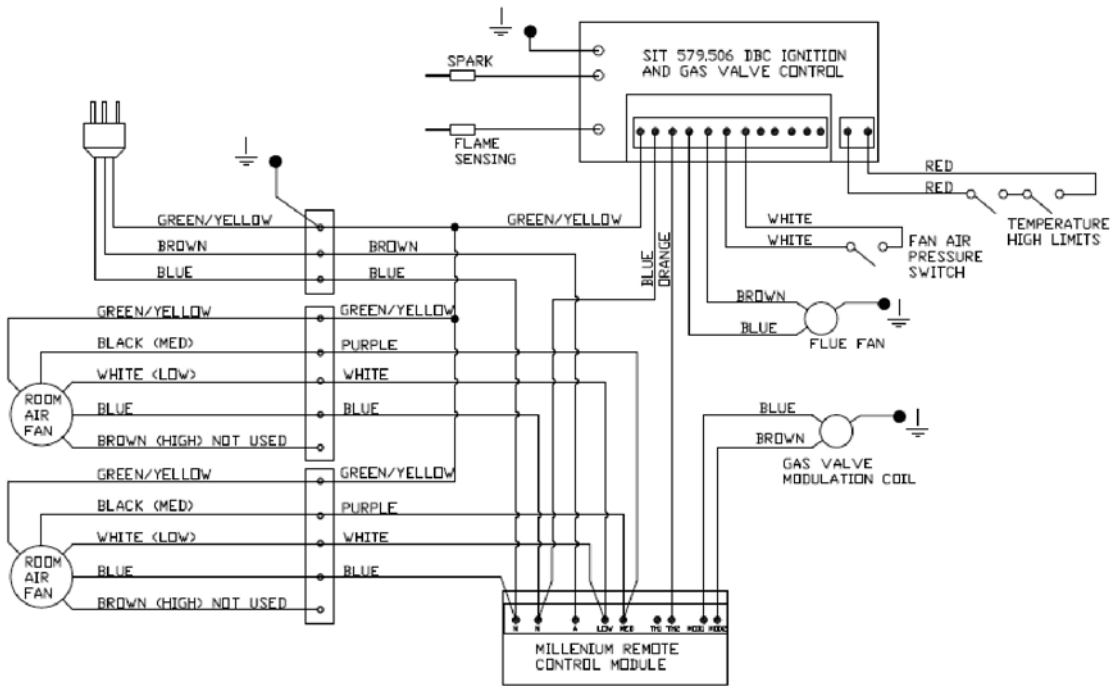

CONVERSION INSTRUCTIONS

Natural gas / Propane / ULPG.



TOOLS

10mm spanner

15mm spanner

16mm Spanner (recommended) or small/medium shifter

No2 Phillip head screwdriver

Allen key 2.5mmAF



BURNER

- 1/ Turn appliance and allow to cool.
- 2/ Turn off gas to appliance
- 3/ Turn off and isolate appliance from electrical supply
- 4/ Remove trim screws (2 off)



- 5/ Remove trim (Slides out)

CONVERSION INSTRUCTIONS (continued)



6/ Remove lower access panel.



7/ Remove door screws (10 off)



8/ Lift off door (Ensure door is cool before attempting)
9/ Remove media where fitted.



10/ Remove end cover plate screw and lift out end plate.
(LH and RH end)

CONVERSION INSTRUCTIONS (continued)



- 11/ Remove burner fixing screws (2 off at ends of burner).



- 12/ Lift burner up and gently support.



- 13/ Undo gas connection pipe at end of burner. (15mm and 16mm spanner required)

CONVERSION INSTRUCTIONS (continued)



- 14/ Lift burner out gently. Avoid marking back wall. Keep burner in the flat position until insulation is restrained (Rotating the burner may cause insulation to fall and be damaged).



15/ RECOMMENDED STEP

To avoid damage to the insulation apply low tack tape to the burner to restrain the insulation into position. Avoid pressing the tape onto the media. The insulation media may easily crack if the appliance have been operated for several hours.

The media may be carefully lifted out and placed flat to store until refitting.

The media can be repainted using an approved high temperature paint, contact Real Flame for details.

16/ Turn burner over gently. AVOIDING DAMAGING THE INSULATION



- 17/ Loosen gas pipe nuts form injectors and move gas pipe away. Note – 15mm spanner required for the nuts, a shifter or spanner should be used to support the brass injector assembly.

CONVERSION INSTRUCTIONS (continued)



- 18/ Undo grub screw (Allen key 2.5mm AF). Injector assembly can now be removed.



- 19/ Remove all injector assemblies.
Unscrew injector and replace with correct gas type.



- 20/ Loosen aeration cap screw approx. ½ turn.
Rotate cap until the correct gap is achieved to suit the gas type.
The listed opening is required on each side of the aeration cap.
(A ruler or similar can be used to check the opening, a drill bit of the designated size can also be inserted to check the opening)
Tighten screw to retain aeration cap setting



Aeration Settings

| | | |
|------------|-------------|-----------|
| NAT GAS | LPG | ULPG |
| 5.0mm open | 10.0mm open | Full open |

CONVERSION INSTRUCTIONS (continued)



- 21/ Refit injector assembly into aeration cap.
- 22/ Refit gas pipe and tighten nuts.
- 23/ Ensure injector assembly is sitting firmly into aeration cap and tighten grub screw.

NOTE – ENSURE INJECTOR ASSEMBLY IS AIMING CENTRALLY INTO THE AERATION CAP AND TUBE

Correct where required.



- 24/ Rotate burner to check insulation is correctly located.
The burner consists of two types of insulation. In the event the lower insulation (white glass wool blanket) has moved push firmly down and ensure blanket fills all gaps and corners of the burner.
- 25/ Sit 12mm hard insulation back into burner. Hard insulation should sit loosely onto the top of soft insulation approximately level with the burner. Where required adjust the soft insulation to ensure sitting correctly. TAKE CARE – where the burner has been previously used the hard insulation is easily cracked. The insulation media can be repainted using an approved high temperature paint, contact Real Flame for details.

CONVERSION INSTRUCTIONS (continued)



PILOT

- 1/ Remove pilot bracket holding screw.



- 2/ Gently lift pilot assembly up to enable access to pipe fittings.



- 3/ Remove spark lead
- 4/ Remove spark probe (10mm spanner required)

CONVERSION INSTRUCTIONS (continued)



- 5/ Remove pilot pipe fitting from pilot assembly.

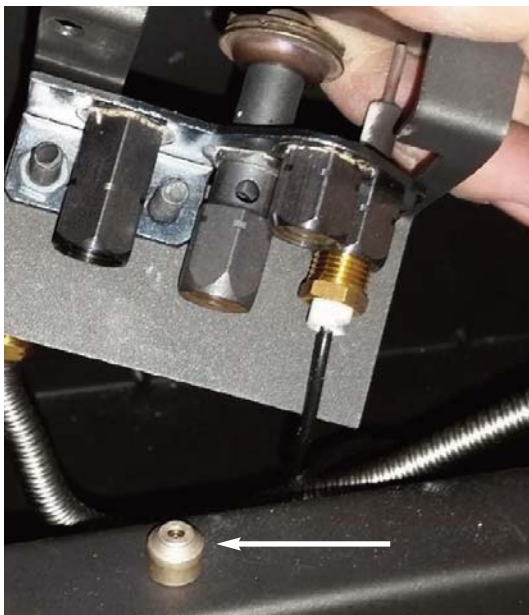

- 6/ Remove pilot orifice from pilot or replace whole pilot assembly with correct gas type.



PILOT REFITMENT

- 1/ Replace pilot orifice with correct gas type.
- 2/ Refit pilot gas pipe and tighten
- 3/ Refit spark probe and gently tighten
- 4/ Refit spark lead
- 5/ Push pilot assembly down to original position and refit the bracket retaining screw.

CONVERSION INSTRUCTIONS (continued)



- 6/ Check all wires are sitting correctly, flush to front wall. Ensure spark lead is not broken or excessively bent. Ensure lead hole is still sealed. (High temperature silicon is suitable for resealing.)



BURNER REFITMENT

- 1/ Carefully place burner into firebox, supporting LH end of the burner.
- 2/ Tighten gas pipe connection to the end of the burner. Burner can now be lowered fully into the firebox.
- 3/ Refit burner retaining screws (2 off)
- 4/ Refit End cover plates and refit holding screws. (Screws only need to be done finger tight)
- 5/ Replace media as per media fitment instructions.
- 6/ Refit door. Check door seal is sitting correctly. Hang door onto firebox. Fit screw and lift door slightly to locate.
10 x screws to be refitted
DO NOT OVERTIGHTEN SCREWS – Hand tight is sufficient for door to seal.

CONVERSION INSTRUCTIONS (continued)



- 7/ Fit manometer to appliance.
- 8/ Start appliance and check for gas leaks in lower area and in firebox.
- 9/ Adjust high and low burner pressures to the dataplate. (The appliance must operate for 3minutes before high pressure setting can be obtained).



Burner
pressure
test point

Max
pressure
adjustment
nut

Min
pressure
adjustment
screw

- 10/ Check appliance for correct flame operation, Check pilot flame, Check main burner is not smothered and flames are even along burner with correct colour and not excessively yellow or sooty. (Note it takes upto 10minutes of operation for the flame to achieve full colour.)
- 11/ Remove manometer and tighten test point. Check test point for gas leaks.
- 12/ Turn appliance off.
- 13/ Refit lower access panel.
- 14/ Refit trim.
- 15/ Refit trim retaining screws (2 off) Screws locate into 2 off prethreaded holes in the appliance casing.

PARTS LIST

| | |
|---|--|
| 1 | Valve |
| 2 | SIT Pilot assembly Natural gas SIT Pilot assembly Propane |
| 3 | Injector Natural gas Injector LPG - ULPG |
| 4 | Millennium receiver (Element) |
| 5 | Millennium remote control (Element) |
| 6 | Sit Ignition pack / gas control |





REAL FLAME PTY LTD

ABN 76 006 311 155

Head Office/Factory/Showroom

1340 Ferntree Gully Rd.
Scoresby Vic 3179
Ph: (03) 8706 2000 Fax: (03) 8706 2001
E-mail: info@realflame.com.au

Richmond - VIC Showroom

300 Swan St.
Richmond Vic 3121
Ph: (03) 9428 4443 Fax: (03) 9428 4445

Dandenong - VIC Showroom

3/328 South Gippsland Highway,
Dandenong South Vic 3164
Ph: (03) 9702 7853
E-mail: sales@realflamedandenong.com.au

Geelong - VIC Showroom

1/2A Gordon Avenue.
Geelong West Vic 3218
Ph/Fax: 5229 0844
E-mail: realflamegeelong@hotmail.com.au

Sydney - NSW Showroom

546 Pacific Highway.
Chatswood NSW 2067
Ph: (02) 8905 0189 Fax: (02) 8905 0192
E-mail: info@realflame.com.au

Miranda - NSW Showroom

36 Kareena Rd
Miranda NSW 2228
Ph: (02) 8513 6202 Fax: (02) 9520 1974
E-mail: paul@realflamemiranda.com.au

Adelaide - SA Showroom

173 -175 Magill Rd.
Norwood SA 5067
Ph: (08) 8132 0371 Fax: (08) 8132 1687
E-mail: realflamesa@iprimus.com.au

Miton - QLD Showroom

46 Douglas St,
Milton QLD 4064
Ph: (07) 3368 2011

Perth - WA Showroom

47-53 McDonald St East,
Osborne Park WA 6017
Ph: (08) 9444 9900 Fax: (08) 9444 9800

Fyshwick - ACT Showroom

88 Wollongong St,
Fyshwick ACT 2609
Ph: (02) 6280 5522

Ulverstone - TAS Showroom

31A Victoria St,
Ulverstone TAS 7315
Ph: (03) 6425 4440