

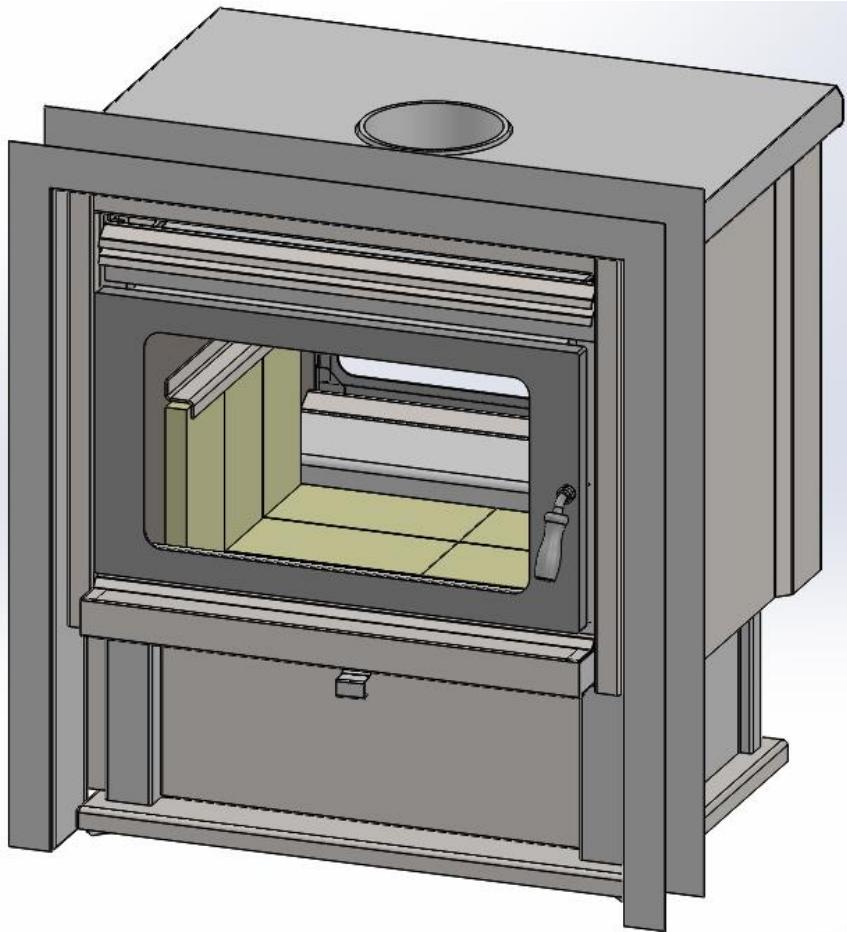

Specialists in fireplace design and manufacture

**COUPE WALL PENETRATION**  
**INSTALLATION & OPERATING INSTRUCTIONS**



**IMPORTANT:**

**INSTALLER, PLEASE LEAVE THESE INSTRUCTIONS WITH THE UNIT ON COMPLETION.**

**10 YEAR FIREBOX WARRANTY**

The firebox is covered by a 10 year warranty.  
Other parts are covered by a one year limited warranty.

Head Office – 13 French Avenue, Brendale, Queensland 4500  
Telephone – PH: (07) 3490 5500  
Facsimile – FAX: (07) 3490 5520  
Website: - [www.kemlan.com.au](http://www.kemlan.com.au)  
Business hours: - Monday to Thursday 7:30am-4:00pm. Friday 7:30am-2:00pm  
Email: - [sales@kemlan.com.au](mailto:sales@kemlan.com.au)

# DIMENSIONS

TWO DOOR DOUBLE SIDED UNIT  
CENTRE FLUE SUIT BUILDING INTO MASONRY

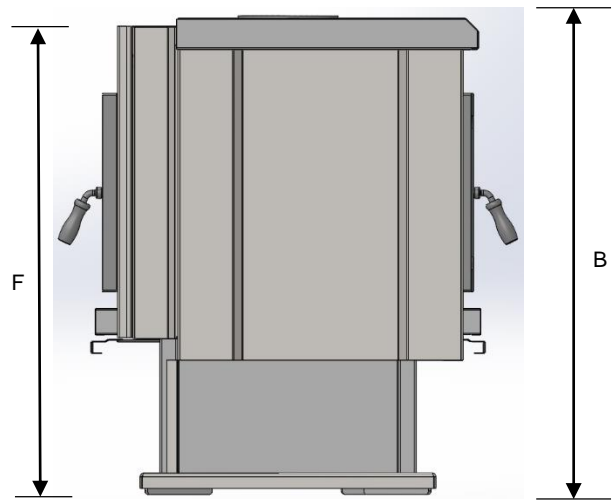
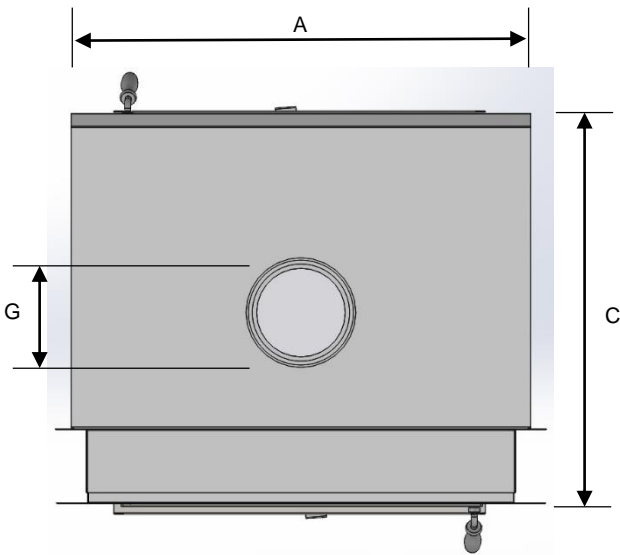
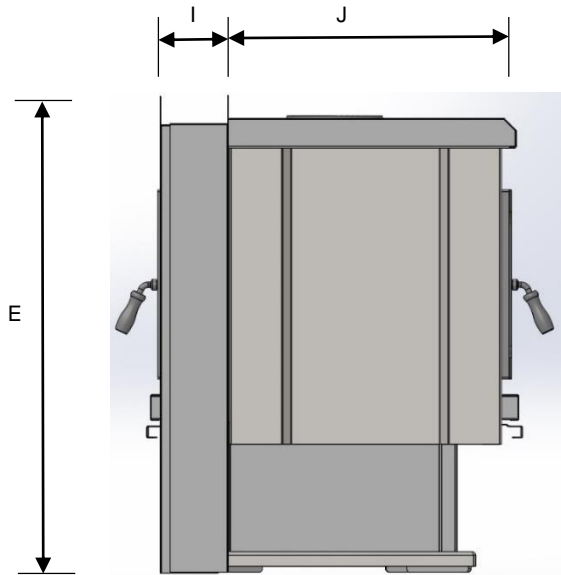
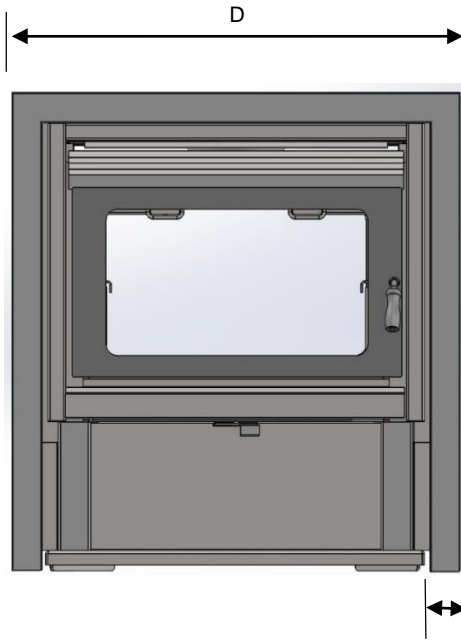

FASCIA NOT SHOWN

	A	B	C	D	E	F	G	I	J
MEASUREMENT	720	780	595	770	820	772	152	100	495

U SECTION / LINTEL TO BE SET INTO BRICK PANEL.  
NOTE WELL : - SURROUND MUST SIT ON TOP OF FINAL HEIGHT OF HEARTH.  
MAY BE INSTALLED THROUGH EXISTING WALL  
TIMBER OR BRICK – AS PER MANUFACTURERS INSTRUCTIONS

# INSTALLATION INSTRUCTION

## COUPE ( 2 DOOR ) WALL PENETRATION INSTALLATION

1. Locate desired position. Check that there are no trusses or beams in the ceiling to obstruct the flue on the free standing side of the wall
2. Cut hole in the wall minimum. 1300mm wide and 1500mm high. NOTE: if brickwork is taken to the ceiling a standard kit may be used. If any combustible wall is left above brickwork a treble kit must be used to prevent wall damage ( figure 2 ).
3. If the floor is wooden secure a 1200mm x 1200mm piece of A C sheet to the floor as per figure 1. this should protrude 370mm from centre line of wall flush side and 830mm from centre line on free standing side.
4. Lay bricks on A C sheet as per figure 1. This will give correct size hearths on both sides of the wall. If floor is cement then tiles or slate may be used instead of bricks.
5. Position combination surround / lintel on TOP of hearth and in a central position. Check levels.
6. Lay masonry as per figure 2. with normal bricks there will be approx. 45mm gap between end of brick & inside vertical face of surround. This may be filled with mortar ( figure 1 ). Adjust mortar so that 9<sup>th</sup> course finishes level with inside horizontal flat section of surround. Finish brick work in normal way using surround as lintel ( figure 2 ).
7. After wall is completed slide fireplace into position. If you remove the doors during this operation it makes life easier. Ensure they are replaced on original sides.
8. Install flue kit as per figure 2.

**NOTE:** When the fireplace is installed in this way there will be a concealed 5mm gap all round between unit and surround to allow for expansion.

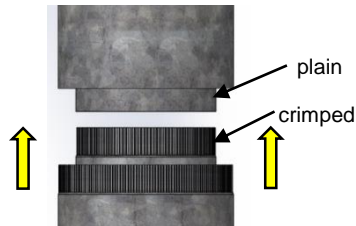
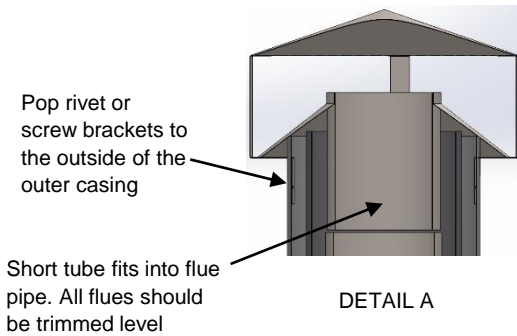

All 8"-10" assembled flues must have the crimps pointing upwards

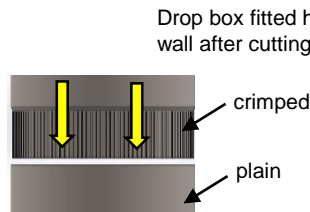

All 6" assembled flues must have the crimps pointing downwards

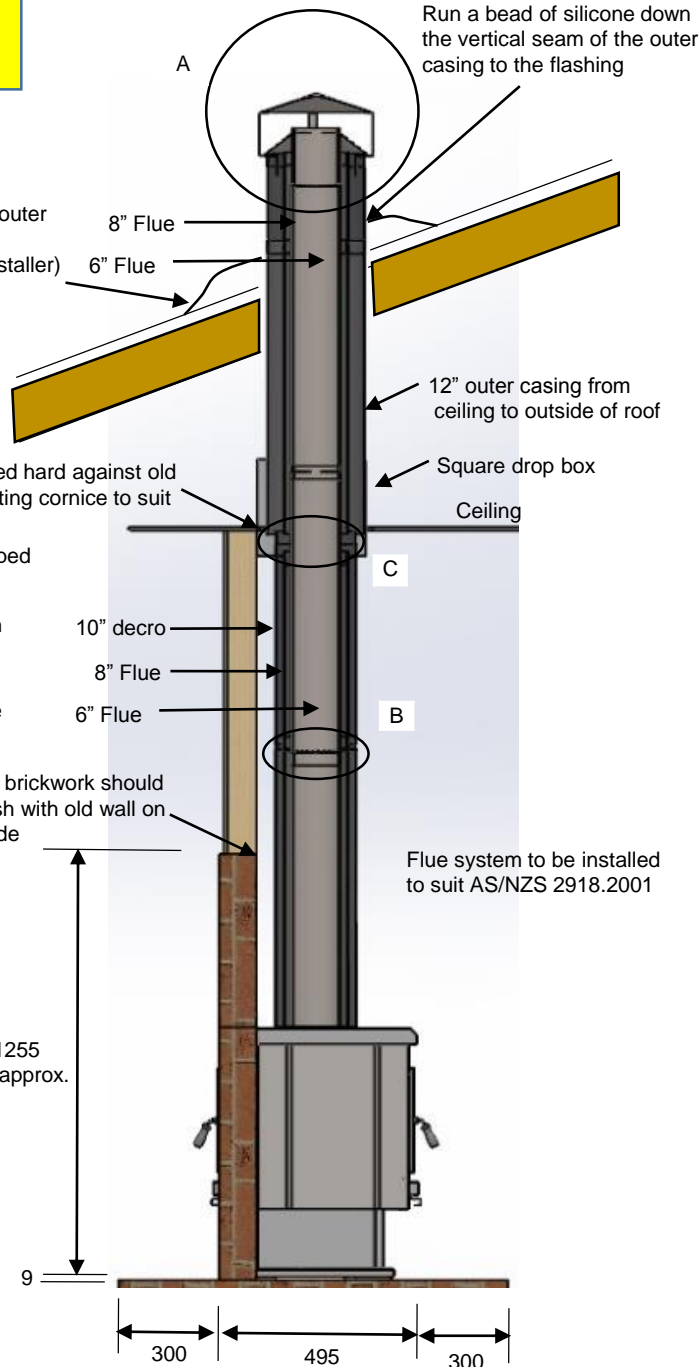
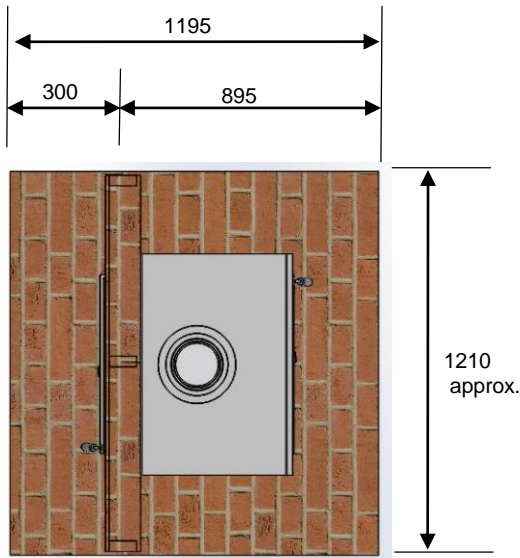
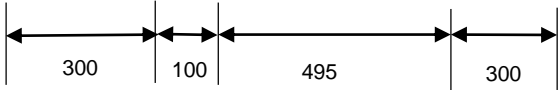
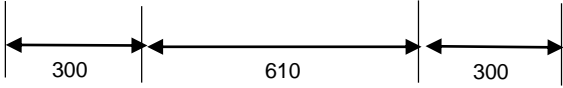
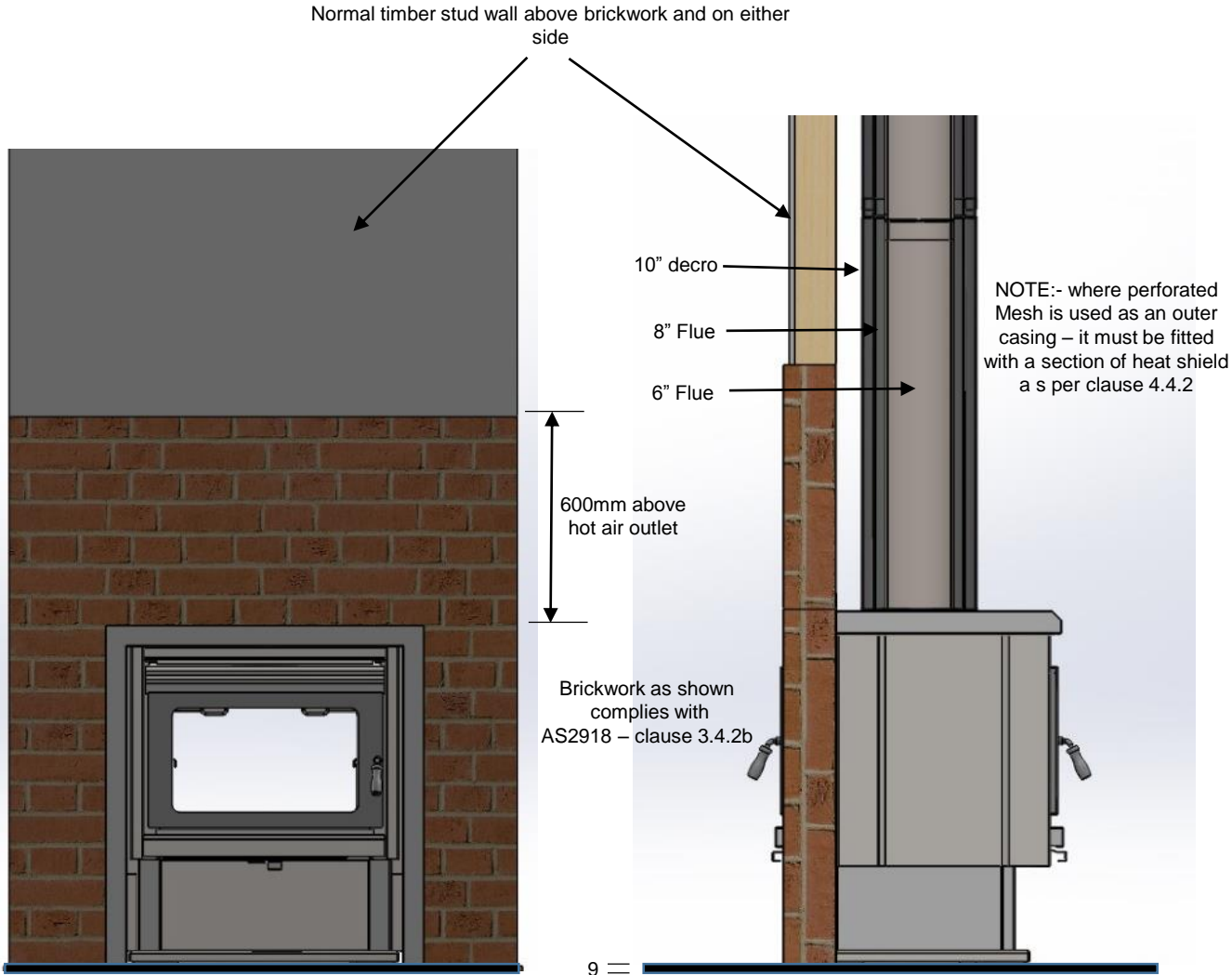

Fig. 2

Fig. 1

# INSTALLATION INSTRUCTION

## COUPE WALL PENETRATION MODEL



HEARTH DIMENSIONS

# INSTALLATION INSTRUCTIONS

## MINIMUM HEIGHT OF FLUE SYSTEM EXIT INSTALLATION TO COMPLY WITH AS/NZS 2918

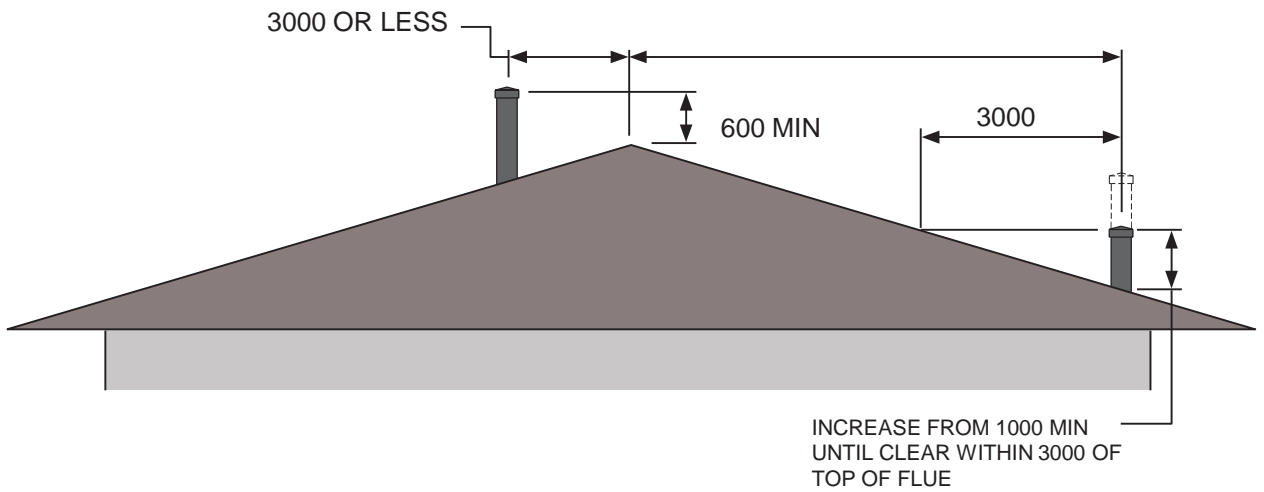
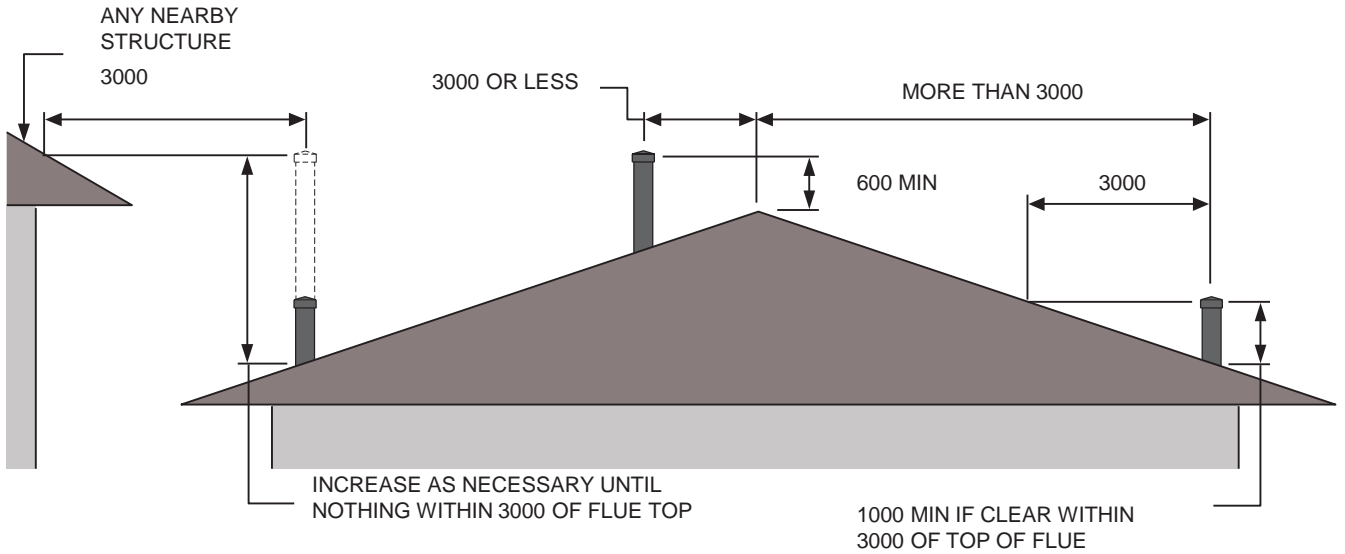

# ABOUT CURING

Your stove has been painted with the highest quality silicone stove paint and has special break-in procedures to cure it with heat and make it hard.

## VENTILATE WELL

Ventilate the house during the first three times the stove is used. The paint on the stove will give off smoke heavy with carbon dioxide and has an odor. Without adequate ventilation, concentrations of smoke could irritate, or be upsetting, so open doors and windows and use a fan if necessary. After these initial burns the paint will be cured and there should be no more smoke.

## DON'T TOUCH DURING CURING

Don't touch the surface. It will be soft and gummy during this paint curing phase. Once cured, it will not be soft again.

## CURE WITH 3 FIRES

Most stoves cure with 3 burns. The first two (2) should be 250°F for 20 minutes, or about half a normal fire. Let the stove cool down between burns. The last fire should be 500°F to 700°F for at least 45 minutes. The point being, cure slowly without a hot fire.

Stoves with cooler surface temperature and those that have been painted with another colour before, will take longer to cure.

Curing can usually be observed by the effect of the paint turning flat as the heat radiates out from hotter parts of the stove.

### **So remember...**

- Ventilate well**
- Do not touch during curing**
- Cure with 3 fires**
- Call your dealer for any questions**

# NATIONAL Certificate of Compliance For Solid Fuel Heaters

This is to certify that the appliance stated on this Certificate has a particulate Emission Factor not greater than the maximum allowable when tested to the appropriate Standard.

Valid to : 2 December 2018

Make	<u>KEMLAN</u>
Model	<u>COUPE SERIES II</u>
Type	<u>DOUBLE SIDED WALL PENETRATION</u>
Category	<u>Slow Combustion Heater</u>
Test Laboratory	<u>HRL Technology</u>
Fuel Type	<u>HARDWOOD</u>
Standards	<u>AS/NZS 4013:2014 AS/NZS 4012:2014</u>

ISSUED BY :



**AUSTRALIAN HOME HEATING ASSOCIATION  
Inc.**

CERTIFICATE No: H939/1215 DATE 2/12/15

.....  
Certification has been issued to Kemlan Industries  
13 French Avenue, Brendale QLD 4500

# INSTRUCTIONS FOR OPERATING YOUR KEMLAN SLOW COMBUSTION WOOD BURNING HEATER

1. Open the air inlet fully by sliding the air inlet control to high.
2. Crumple at least three double pages of newspaper into loose balls and place them into the centre of the firebox.

Cross lay at least 15 to 20 pieces of kindling on top of the paper – if pine is used, the size should vary from the thickness of a pencil to that of a knife handle – if hardwood is used split it even smaller.

3. Light the paper and close the door.

Once the kindling is well alight, add a few pieces of slightly larger hardwood, split to approximately 25mm x 50mm (2" x 1").

4. Close the door and leave the air inlet control on high. When the hardwood is well alight (usually 5 to 10 minutes) and coals are starting to form, larger pieces of hardwood may be added – five or six pieces the equivalent of 50mm x 50mm (2" x 2") is ideal.

The object is to create a fiercely burning fire of reasonable small hardwood, which will quickly produce a good bed of glowing coals on the floor of the firebox. This will take from 20 to 40 minutes depending on the quality of the firewood.

5. Larger pieces of hardwood may now be added. Half fill the firebox and leave the air inlet control on high until the wood is well alight then close the control approximately a third of its travel.

Usually about one hour after lighting, the air inlet control can be further shut down to achieve the desired heat output.

When adding new firewood it is desirable to fully open the air inlet for approximately 10 to 15 minutes until the new pieces are burning well, then it may be returned to its desired setting.

6. To set the fire for overnight burn – two-thirds fill the firebox with hardwood and fully open the air inlet.

Once the fire is burning well, the air inlet control should be shut down approximately three-quarters of its travel. Setting the air inlet control may be varied to suit your particular requirements and the quality and size of your firewood.

Remember wet or green wood may cause a dramatic reduction in the heat output of your heater (refer to "Operating Hints" for more details).

7. Have the flue inspected at least once every 12 months as it may require cleaning.
8. Clean out excess ash from the floor of the firebox when required. Do not remove all the ash and in particular leave any pieces of charcoal in the heater as they are good fuel.
9. If the glass door in your heater becomes dirty, your firewood is either green, wet or both. You may be closing the air inlet down too soon after lighting or after adding new firewood.

To clean the glass, simply use some of the white ash in the firebox. Apply it with a damp cloth in a circular motion. Remove residue with a clean cloth or paper. Do not clean the glass when the heater is operating.

10. To clean the painted surface, simply dust with a soft duster and wipe over with a damp cotton cloth. Only clean when the heater is cool.

## **IMPORTANT:**

**UNDER NO CIRCUMSTANCES SHOULD ANY SOLVENTS SUCH AS METHYLATED SPIRITS, PETROL, MINERAL TURPENTINE ETC BE ALLOWED TO COME IN CONTACT WITH THE PAINTED SURFACE OF THE HEATER AS DAMAGE TO THE FINISH WILL RESULT. IF AN ACCIDENT DOES OCCUR, SPRAY CAN PAINT IS AVAILABLE FROM YOUR NEAREST KEMLAN DEALER.**



# OPERATING HINTS

To get the best from your Kemlan heater it is essential that you use good firewood, and use it correctly. Many people do not understand the principle of using a wood burning appliance and we suggest that it will be worth your while to study the following extract from a well known American publication.

## PRINCIPLES OF COMBUSTION: HOW WOOD BURNS

Technically, wood does not burn. What burns is the volatiles and charcoal that are created. That is why wood will not catch on fire immediately when you put a match to it; it has to first undergo the chemical changes that create the volatiles, and a match does not create enough heat to activate the process. As kindling and paper evaporate the moisture in the wood, the wood absorbs heat. At a certain point, gases are given off and when these volatiles reach 480 degrees F, or the "Flash point", as it is called, they will burst into flame if sufficient oxygen is present. The volatiles give off more heat than does charcoal, which is why a fire with flames (which burn the volatiles) produces more heat than one that is all charcoal.

Since the volatiles are gases and since heat rises, taking the gases with it, it is very easy to create a situation in which most of the volatiles go up the chimney almost as soon as they are produced. This is what happens with a roaring fire and, to a lesser extent, with an open fire. One of the reasons (but only one) that a freestanding wood stove produces more heat than an open fire is that the volatiles are contained within the firebox and are not so quickly dissipated up the chimney. A stove that is baffled is merely one that has interior construction design to keep the volatiles in the firebox longer; the longer they are in the firebox, the more completely they burn. The more completely they burn, the more heat is produced. It's that simple.

Since the flames burn the volatiles and produce heat, the ideal situation is the longest possible flame path. As soon as wood burners understand this, they tried to devise ways of making the flame path longer than in an ordinary open fire. Even though the role of oxygen in combustion was not understood in Ben Franklin's time, Franklin did realize the importance of more completely burned volatiles. His solution was to try to invent a downdraft stove – one that sent the volatiles back down through the fire – but he never succeeded in getting it to work. A downdraft goes against the nature of volatiles, which is to rise. In more recent times, there have been some successful downdraft – or partial downdraft – stoves created and some of the fireplace stoves and units utilize this principle. Ideally, it would be best if the volatiles could be redirected down through the fire several times, until they were almost totally consumed. This would not only make the maximum use of the heat potential of the wood; it would reduce creosote build-up to almost zero. Perhaps someday an ingenious inventor will design a unit that does this; so far no has been able to.

## MOISTURE AND COMBUSTION

As we have seen, dry wood ignites faster and burns better – with higher heat production – than wet or green wood. The difference between the amount of heat produced by dry wood and green wood is so great that a dry softwood of good grade will produce more heat than green hardwood. Green white ash, for instance, is not as good a fuel as dry tamarack.

The reason for the superiority of dry wood is easy to understand. Heat cannot be produced until moisture has been driven off. Since even so-called seasoned dry wood contains approximately 20 percent moisture, it takes time for any fire to begin producing useable heat. Wet wood, which can have a moisture content of over 100 percent (due to the way moisture is measured), will take that much longer to produce heat. Meanwhile, the fire will produce smoke and creosote and very little heat. This was brought sharply to my attention when I installed my first wood heater. To my surprise and delight, I found it comfortably heated eight rooms, where I had expected to heat only two or three. After some time, when I had someone helping me run the fire, I suddenly noticed that the house was chilly. We added more wood and adjusted the draft controls, but nothing we did seemed to help. It finally occurred to me to check the woodpile. My friend had been getting green wood from a stack that was drying, instead of from the dry-wood stack. The difference the green wood made was so dramatic I will never forget it.

## HOW TO TEST WOOD FOR DRYNESS

There are two easy ways for even a novice to spot dry wood. Dry wood tends to "check". Look at the log ends and you will see cracks radiating from the centre of the log. If the logs have been split, the cracks will be harder to find because wood tends to split along the cracks.

Another test for dry wood is the sound it makes when two logs are banged against each other. Green wood will make sort of a dull thud; dry wood makes a nice crisp, sharp sound. Once you have heard the two, you will remember the difference.

## FROM THE ABOVE EXTRACT SEVERAL FACTS BECOME APPARENT:

1. It is vital that your firewood be dry and seasoned.
2. A good hot fire of kindling and smaller pieces of fuel must be established before adding larger logs.
3. The larger logs should be well alight before slowing down the combustion by adjusting the air intake.
4. A hot bed of coals needs to be maintained to ensure continued combustion in the firebox.
5. When new timber is added to the firebox the air control should be opened until the fuel is well alight before damping it down again. This will take from 10 to 20 minutes.
6. When setting the controls for overnight burn you will need to experiment with the settings to suit your particular type of fuel. Very dense hardwood requires more air to combust and over damping will result in charring and smoking causing the glass in the door to become dirty. The same will apply with fuel which is not fully seasoned or is not dry enough. Kemlan have followed a policy since 1969 of checking on all complaints about poor performance of their heaters and apart from a few instances of incorrect installation (mostly insufficient flue length) all problems have been directly related to incorrect operation and/or poor fuel. We know you will experience many years of satisfaction from your heater if you follow the above advice.

# WARRANTY

1. Kemlan wood heaters carry a warranty on the 6mm firebox for a period of ten (10) years.
2. This warranty also covers other components of the heater for a period of one (1) year. These components include the baffle plate, handle assembly, secondary air tubes and fan.
3. Kemlan's warranty covers the wood heaters against defects in materials and manufacture.

## 4. THIS WARRANTY DOES NOT COVER –

- 4.1 Failure to comply with manufacturer's operation instructions.
- 4.2 Normal wear and tear or damage caused by incorrect installation.
- 4.3 Any form of rust and/or corrosion to the painted finish of the heater.
- 4.4 Damage to the glass in the door, if the damage is caused by impact or misuse.
- 4.5 The cost of collection and delivery of the wood heater and/or parts.
- 4.6 Damage caused by water ingress.
- 4.7 Cost of removal of defective heater or re-installation of replacement heater.
- 4.8 Failure to use fireplace components supplied by Kemlan Industries Pty Ltd.
- 4.9 Cost of inspection for damaged heater.

## 5. CLAIMS –

- 5.1 (i) Kemlan will provide a full replacement of the heater in the first five years after installation.  
  
(ii) Replacement in the subsequent five years (i.e. sixth to tenth year after installation will be on the following basis.  
Owner will pay fifty percent of purchase price if the claim is made in the sixth year – tenth year after purchase.
- 5.2 Replacement of heater subject to all conditions in section four of warranty.
- 5.3 Should any defects occur, contact the Kemlan distributor from whom you purchased the heater.
- 5.4 Under this warranty the defective parts will be repaired or replaced by Kemlan's option, free of charge.
6. The fireplace installation must comply with the relevant local statutes, ordinances, regulations and by-laws.

## PLEASE COMPLETE AND RETAIN THIS SECTION FOR YOUR RECORDS

Purchased from: .....  
Address: .....  
Date of Purchase: .....