

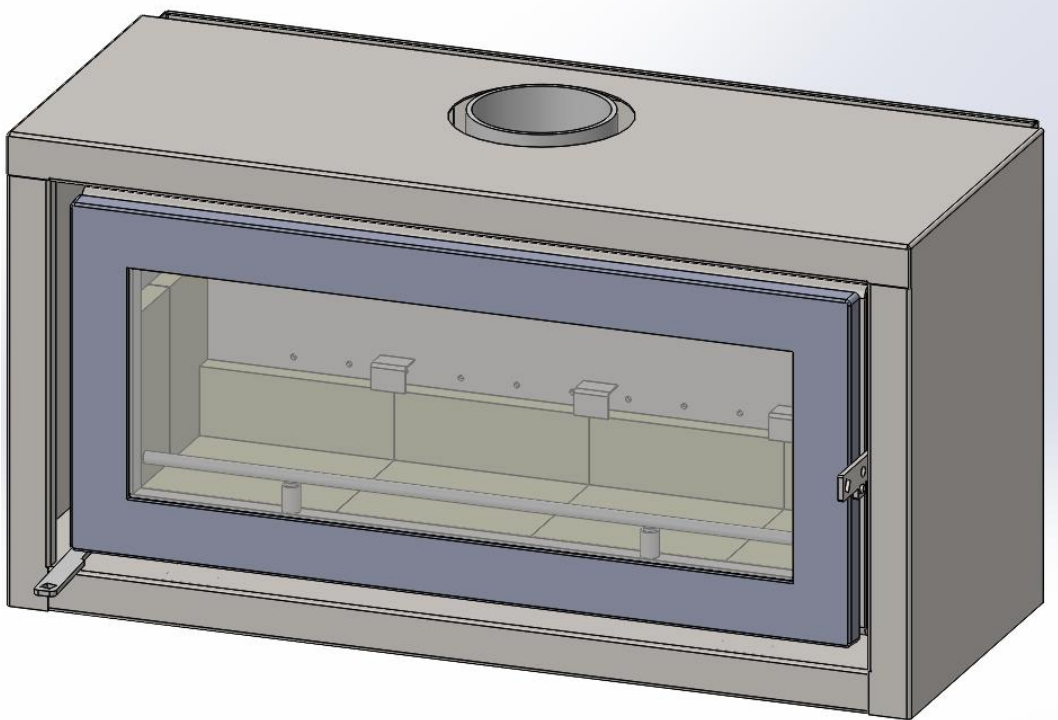

Specialists in fireplace design and manufacture

CELESTIAL 900 FREESTANDING **INSTALLATION & OPERATING INSTRUCTIONS**



IMPORTANT:

INSTALLER, PLEASE LEAVE THESE INSTRUCTIONS WITH THE UNIT ON COMPLETION.

10 YEAR FIREBOX WARRANTY

The firebox is covered by a 10 year warranty.
Other parts are covered by a one year limited warranty.

Head Office – 13 French Avenue, Brendale, Queensland 4500

Telephone – PH: (07) 3490 5500

Facsimile – FAX: (07) 3490 5520

Website: - www.kemlan.com.au

Business hours: - Monday to Thursday 7:30am-4:00pm. Friday 7:30am-2:00pm

Email: - sales@kemlan.com.au

DIMENSIONS

CELESTIAL 900 FREESTANDING WITH METAL CASING

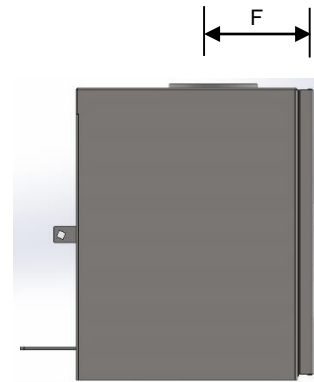
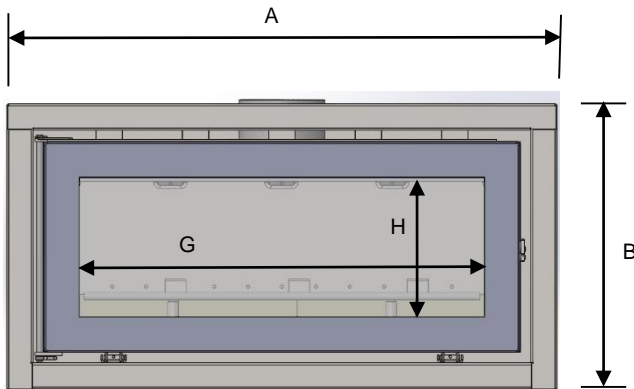
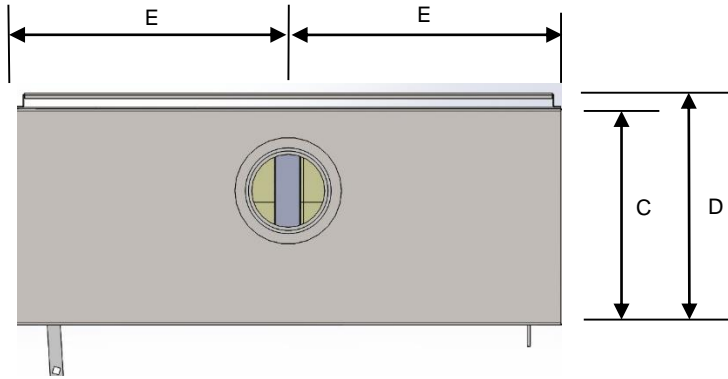

	A	B	C	D	E	F	G	H
MEASUREMENTS	1053	547	414	444	526.5	187	776	268

MINIMUM CLEARANCES FOR THE CELESTIAL 900 FREESTANDING SOLID FUEL APPLIANCE INSTALLED WITH DEFAULT FLUE KIT

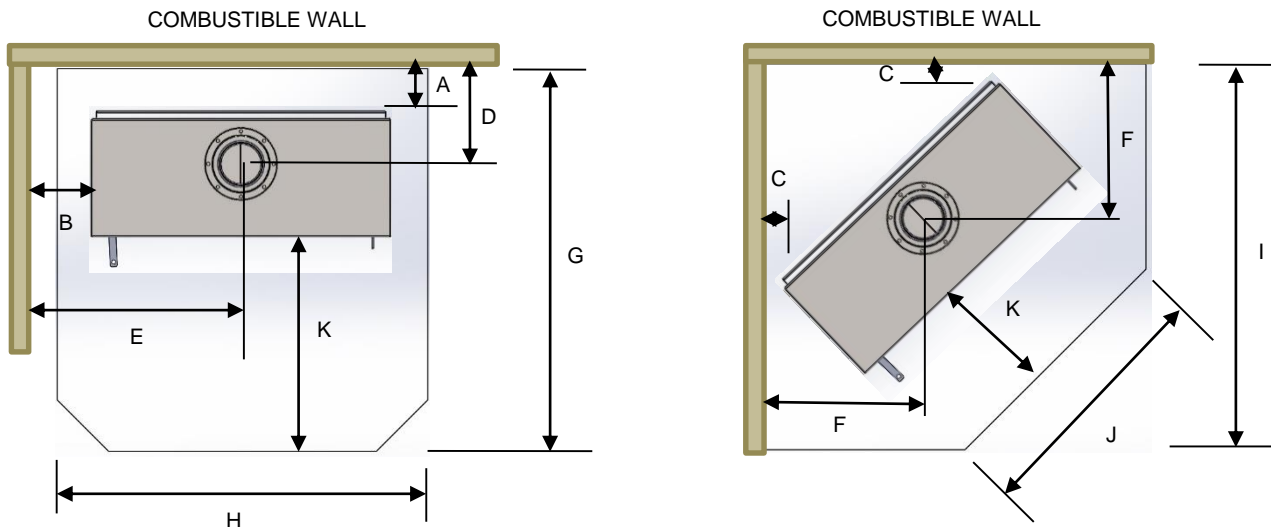

MINIMUM CLEARANCES:

	A	B	C	D	E	F	G	H	I	J	K
MEASUREMENT	70	350	50**	257	876	530	1115	1080	1375	910	725*

*As per Clause 3.3.2 of AS/NZS 2918:2001 for floor protector construction requirements. This measurement only applies when unit is 200mm above floor. (refer hearth measurement drawing if unit is higher than 200mm from floor.)

** This is the minimum allowable distance to any combustable material behind the unit.

Glass viewing area- 728mm wide x 268mm high
 Flue pipe- ø150mm – top exit
 Shipping weight- 185 kg

All dimensions shown are approximate. Check all dimensions accurately before installation. Before installing refer to the installation instructions.

In line with our policy of continuous improvement, we reserve the right to alter specifications without notice.

CONSTRUCTION:

6 mm heavy duty steel firebox – fully welded
 25mm thick firebrick lined floor, back and sides
 19mm ceramic baffle plates

NOTE:

The floor protector consists of a 18mm thick Bellis Board or similar material which has a thermal resistance of 0.1m² k/W, per 9mm thick sheet

PERFORMANCE:

Heating capacity – 220-320m² (23-33 squares)
 Average peak heat output – 12.7kW
 Average Particulate emission - 0.6g/kg
 Average efficiency – 60%

Heating capacity of this appliance is given as a guide only and may vary depending on the climate zone and type of dwelling (floor plan and degree of insulation). Consult your local authorised distributor to determine realistic expectations for your home.

Heat output and fuel consumption of this appliance is dependent on the moisture content, size, loading geometry and the type of hardwood used.

The appliance complies to the safety standards AS/NZS 2918. When in use some parts may become hot. A suitable fireguard is recommended where the very young, elderly or infirm are concerned.

HEARTH MEASUREMENT

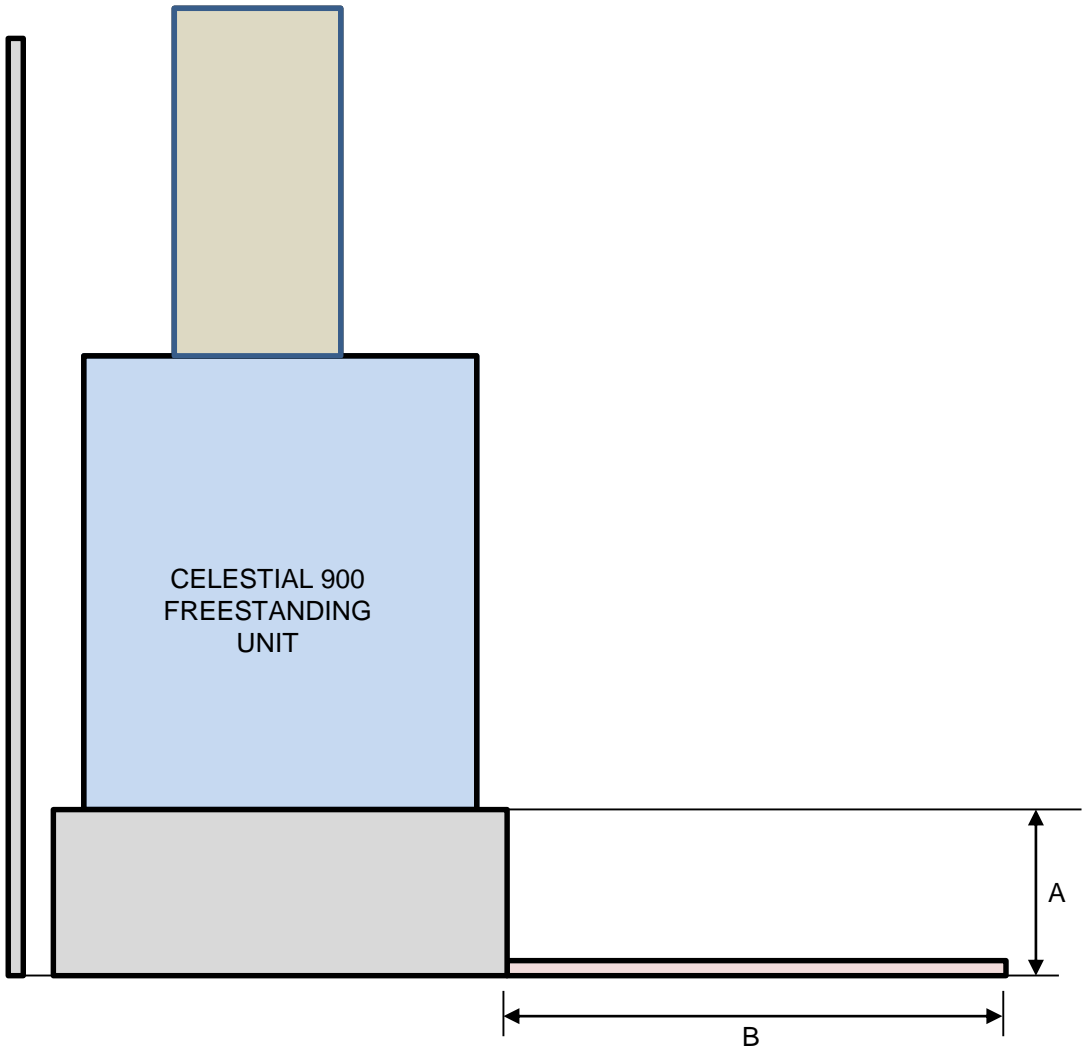

A.	UNIT HEIGHT ABOVE FLOOR	200	300	400	500	600	700
B.	HEARTH DIMENSION FORWARD OF UNIT	725	715	665	594	492	335

HEARTH REQUIREMENTS FOR INSTALLATION ONTO A RAISED HEARTH

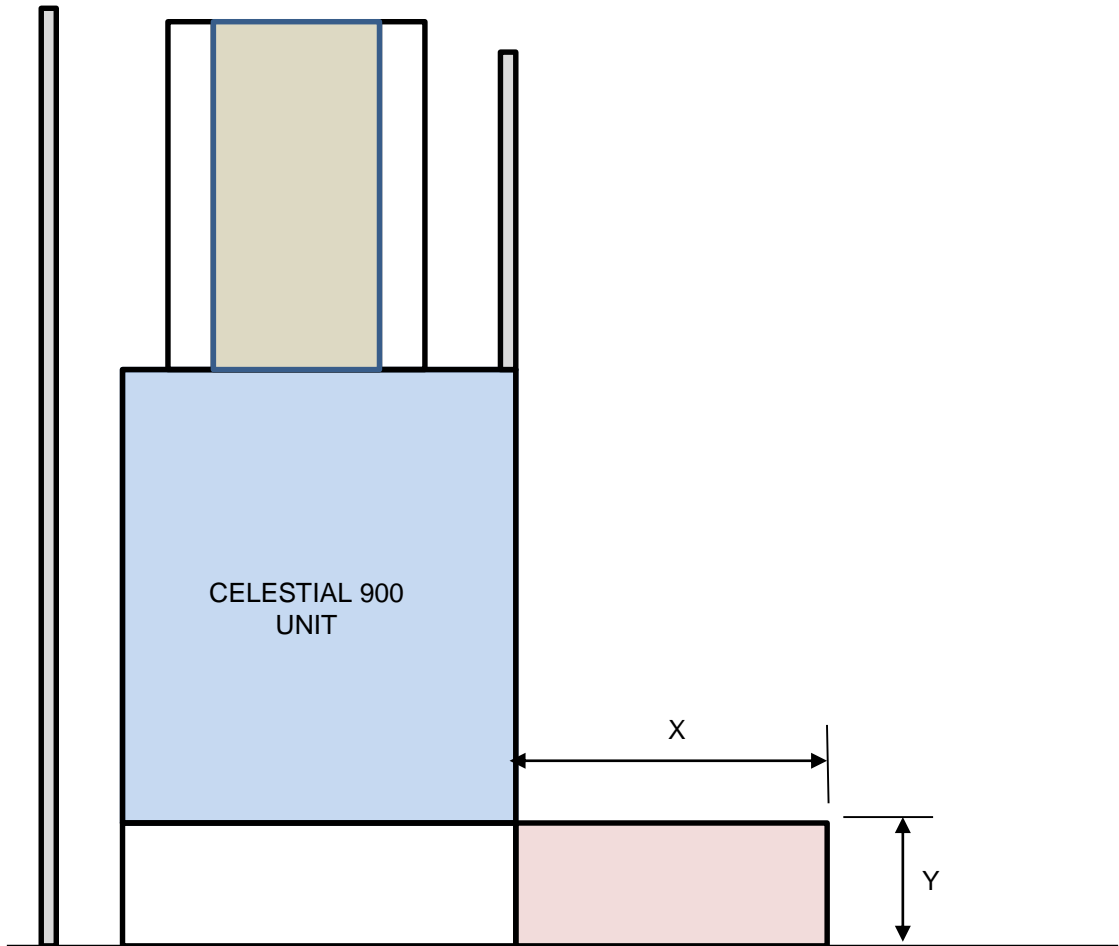

X.	MIN. DEPTH MEASUREMENT (mm)	300
Y.	MIN. HEIGHT INCREASE (mm)	200*

* NOTE: IF Y IS LESS THAN 200mm THEN REFER TO HEARTH MEASUREMENT ON PREVIOUS PAGE

BAFFLE PLATE INSTALLATION

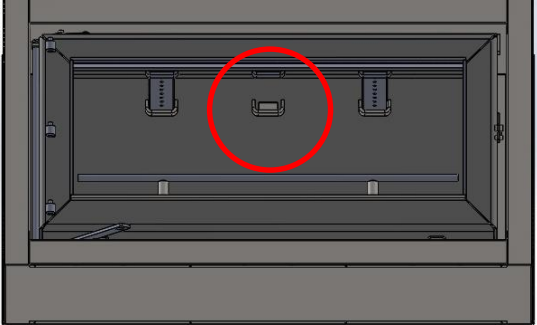

1. REMOVE MIDDLE AIR TUBE BY PUSHING UP AND REMOVING FROM FRONT AND REAR BRACKETS.

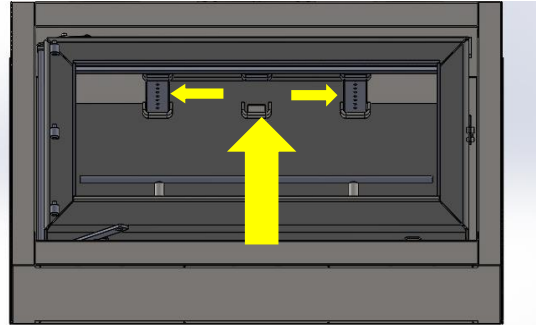

2. PLACE ALL 4 BAFFLE PLATES ABOVE AIR TUBES BOTH SIDES CLOSEST TO THE FIRE BOX WALL AS SHOWN (2 LEFT AND 2 RIGHT)

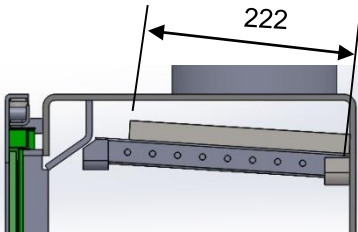

3. PLACE BAFFLE PLATES AS FAR BACK AS POSSIBLE, 222 MM FROM FRONT TO BACK.



4. BAFFLE PLATE SIDE OF 212 MM SHOULD EXTEND FROM SIDE TO SIDE,

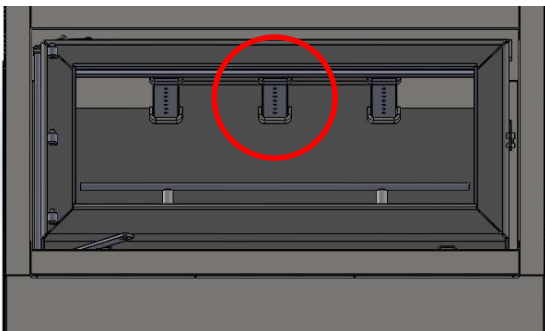

5. RE- PLACE MIDDLE AIR TUBE BACK INTO POSITION
(NB. MAKE SURE OPEN END OF AIR TUBE IS PLACED INTO REAR OPENING. CLOSED END TOWARDS DOOR. FAILURE TO INSTALL AIR TUBES CORRECTLY WILL VOID WARRANTY.)

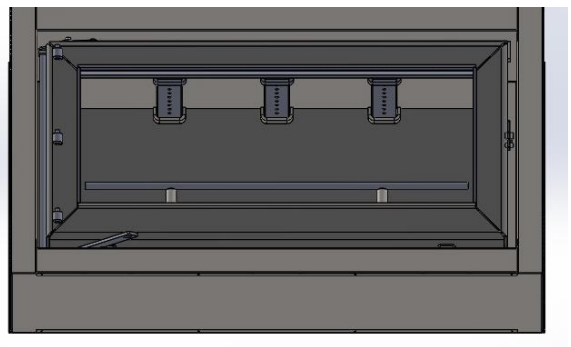

6. SLIDE THE BAFFLE PLATES ATOP THE OTHER 2 BAFFLE PLATES INTO THE MIDDLE POSITION AS SHOWN. LEAVE GAP OF 1-2 MM IN BETWEEN PLATES. THE GAPS SHOULD BE ROUGHLY IN THE MIDDLE OF THE AIR TUBES. UNIT IS NOW READY FOR USE.

CELESTIAL 900 FREESTANDING INFORMATION FOR FLAT CEILING

STAINLESS STEEL DOUBLE
CONE COWL

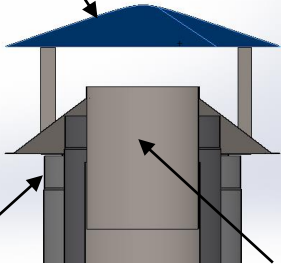

POP RIVET OR SCREW
BRACKETS TO THE
OUTSIDE OF THE
OUTER CASING

DETAIL A

RUN A BEAD OF SILICONE DOWN
THE VERTICAL SEAM OF THE OUTER
CASING TO THE FLASHING

ROOF FLASHING
SUPPLIED BY
CONTRACTOR

SHORT TUBE FROM
THE COWL FITS
INTO FLUE PIPE. ALL
FLUES SHOULD BE
TRIMMED LEVEL

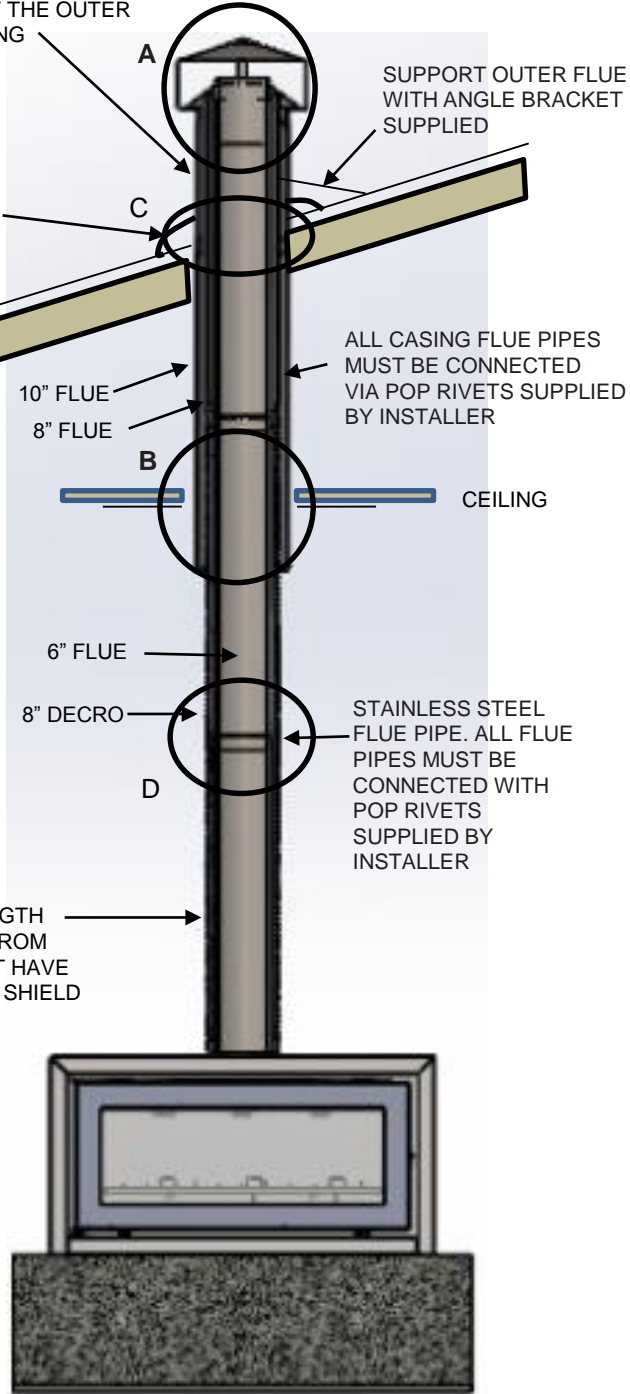

SUPPORT OUTER FLUE
WITH ANGLE BRACKET
SUPPLIED

ALL CASING FLUE PIPES
MUST BE CONNECTED
VIA POP RIVETS SUPPLIED
BY INSTALLER

10" FLUE
8" FLUE

CEILING

6" FLUE

8" DECRO

STAINLESS STEEL
FLUE PIPE. ALL FLUE
PIPES MUST BE
CONNECTED WITH
POP RIVETS
SUPPLIED BY
INSTALLER

THE FIRST LENGTH
OF 8" DECRO FROM
THE UNIT MUST HAVE
DOUBLE HEAT SHIELD



ALL 6" ASSEMBLED FLUES
MUST HAVE THE CRIMPS
POINTING DOWNWARDS

ALL 8"-10" ASSEMBLED FLUES
MUST HAVE THE CRIMPS
POINTING UPWARDS

DETAIL D

DETAIL C

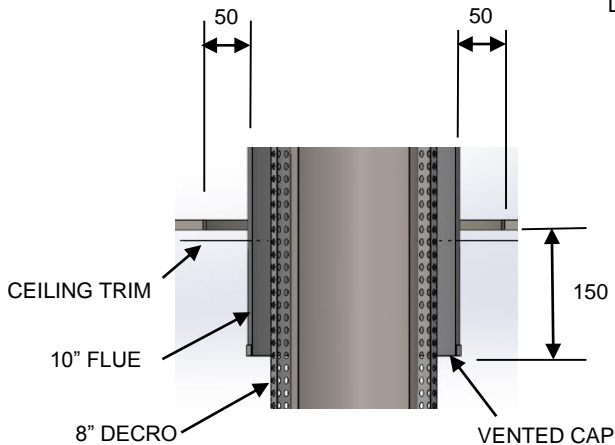

DETAIL B

FRONT VIEW

CELESTIAL 900 FREESTANDING INFORMATION FOR RAKED CEILING

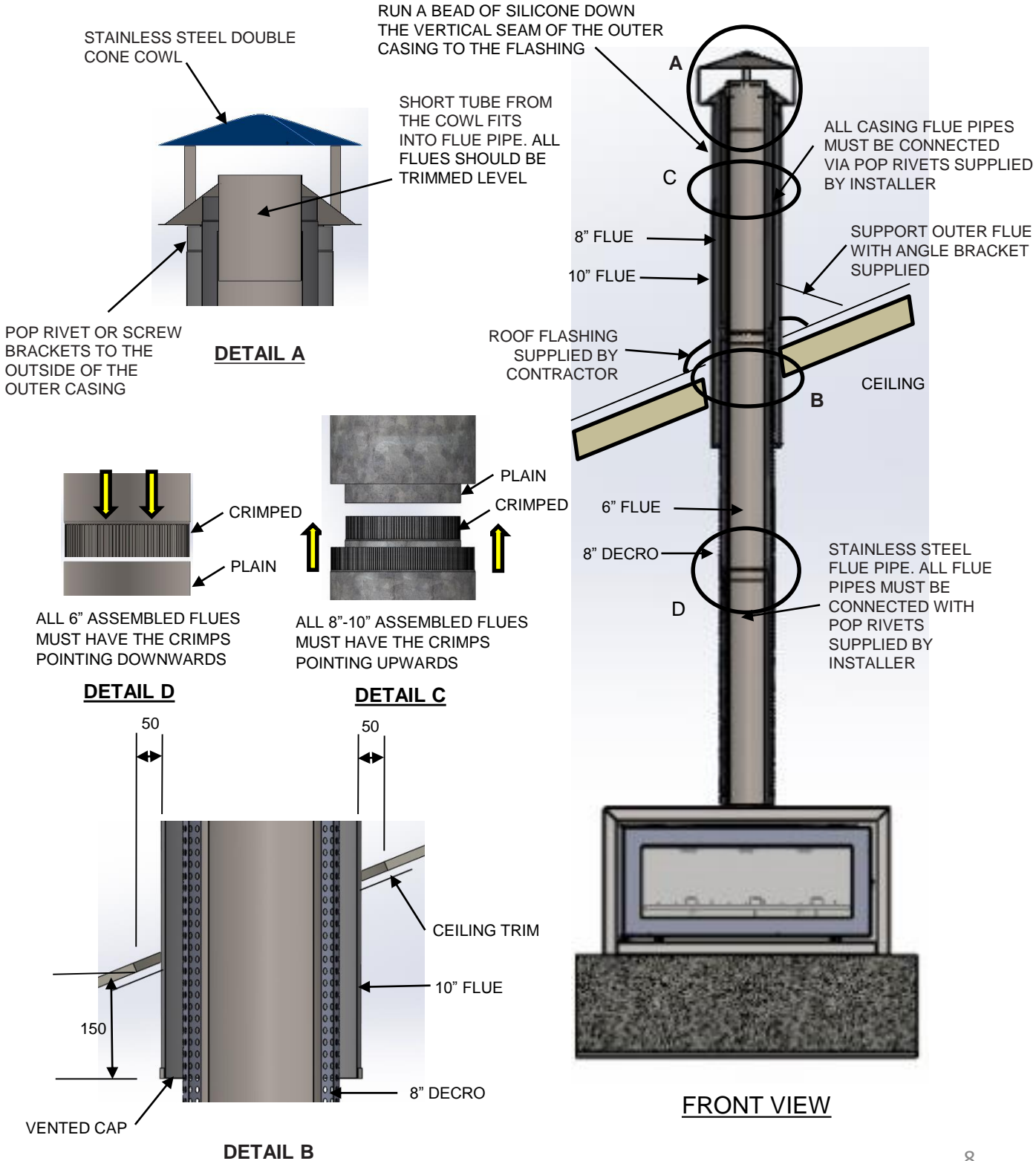

INSTALLATION INSTRUCTIONS

MINIMUM HEIGHT OF FLUE SYSTEM EXIT INSTALLATION TO COMPLY WITH AS/NZS 2918

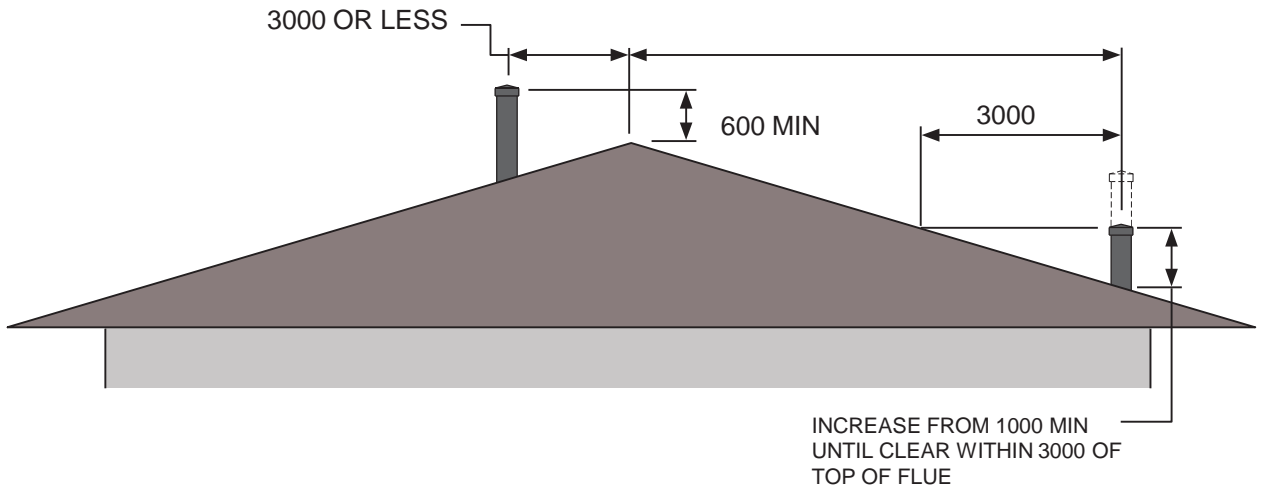
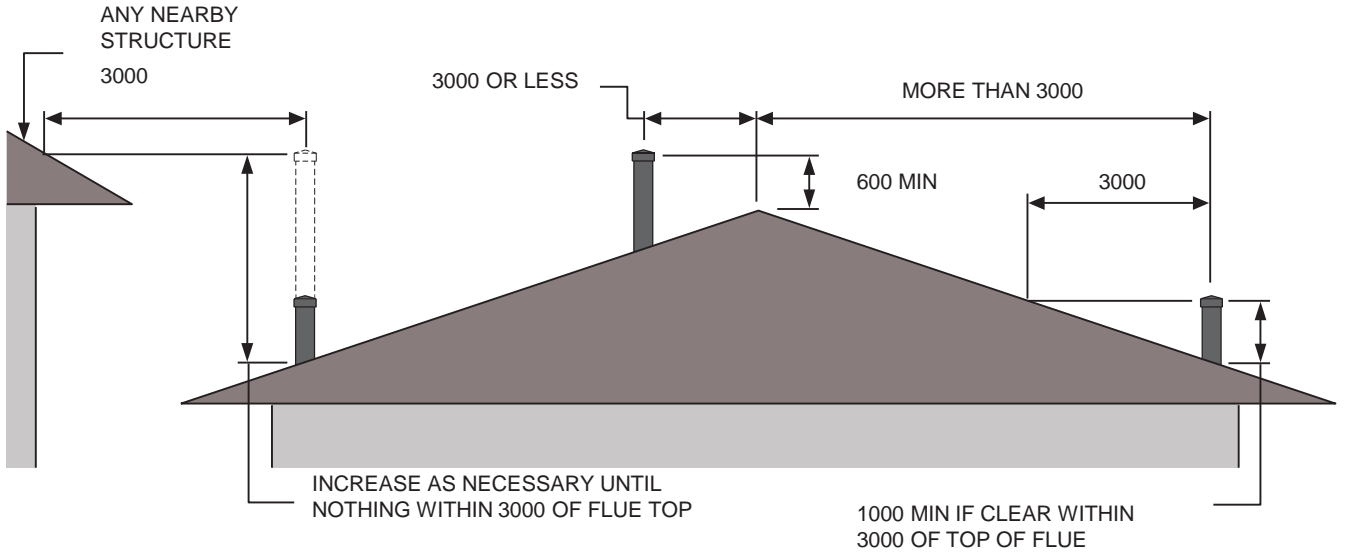

ABOUT CURING

Your stove has been painted with the highest quality silicone stove paint and has special break-in procedures to cure it with heat and make it hard.

VENTILATE WELL

Ventilate the house during the first three times the stove is used. The paint on the stove will give off smoke heavy with carbon dioxide and has an odor. Without adequate ventilation, concentrations of smoke could irritate, or be upsetting, so open doors and windows and use a fan if necessary. After these initial burns the paint will be cured and there should be no more smoke.

DON'T TOUCH DURING CURING

Don't touch the surface. It will be soft and gummy during this paint curing phase. Once cured, it will not be soft again.

CURE WITH 3 FIRES

Most stoves cure with 3 burns. The first two (2) should be 250°F for 20 minutes, or about half a normal fire. Let the stove cool down between burns. The last fire should be 500°F to 700°F for at least 45 minutes. The point being, cure slowly without a hot fire.

Stoves with cooler surface temperature and those that have been painted with another colour before, will take longer to cure.

Curing can usually be observed by the effect of the paint turning flat as the heat radiates out from hotter parts of the stove.

So remember...

- **Ventilate well**
- **Do not touch during curing**
- **Cure with 3 fires**
- **Call your dealer for any questions**

INSTRUCTIONS FOR OPERATING YOUR KEMLAN SLOW COMBUSTION WOOD BURNING HEATER

1. Open the air inlet fully by sliding the air inlet control to high.
2. Crumple at least three double pages of newspaper into loose balls and place them into the centre of the firebox.

Cross lay at least 15 to 20 pieces of kindling on top of the paper – if pine is used, the size should vary from the thickness of a pencil to that of a knife handle – if hardwood is used split it even smaller.

3. Light the paper and close the door.

Once the kindling is well alight, add a few pieces of slightly larger hardwood, split to approximately 25mm x 50mm (2" x 1").

4. Close the door and leave the air inlet control on high. When the hardwood is well alight (usually 5 to 10 minutes) and coals are starting to form, larger pieces of hardwood may be added – five or six pieces the equivalent of 50mm x 50mm (2" x 2") is ideal.

The object is to create a fiercely burning fire of reasonable small hardwood, which will quickly produce a good bed of glowing coals on the floor of the firebox. This will take from 20 to 40 minutes depending on the quality of the firewood.

5. Larger pieces of hardwood may now be added. Half fill the firebox and leave the air inlet control on high until the wood is well alight then close the control approximately a third of its travel.

Usually about one hour after lighting, the air inlet control can be further shut down to achieve the desired heat output.

When adding new firewood it is desirable to fully open the air inlet for approximately 10 to 15 minutes until the new pieces are burning well, then it may be returned to its desired setting.

6. To set the fire for overnight burn – two-thirds fill the firebox with hardwood and fully open the air inlet.

Once the fire is burning well, the air inlet control should be shut down approximately three-quarters of its travel. Setting the air inlet control may be varied to suit your particular requirements and the quality and size of your firewood.

Remember wet or green wood may cause a dramatic reduction in the heat output of your heater (refer to "Operating Hints" for more details).

7. Have the flue inspected at least once every 12 months as it may require cleaning.
8. Clean out excess ash from the floor of the firebox when required. Do not remove all the ash and in particular leave any pieces of charcoal in the heater as they are good fuel.
9. If the glass door in your heater becomes dirty, your firewood is either green, wet or both. You may be closing the air inlet down too soon after lighting or after adding new firewood.

To clean the glass, simply use some of the white ash in the firebox. Apply it with a damp cloth in a circular motion. Remove residue with a clean cloth or paper. Do not clean the glass when the heater is operating.

10. To clean the painted surface, simply dust with a soft duster and wipe over with a damp cotton cloth. Only clean when the heater is cool.

IMPORTANT:

UNDER NO CIRCUMSTANCES SHOULD ANY SOLVENTS SUCH AS METHYLATED SPIRITS, PETROL, MINERAL TURPENTINE ETC BE ALLOWED TO COME IN CONTACT WITH THE PAINTED SURFACE OF THE HEATER AS DAMAGE TO THE FINISH WILL RESULT. IF AN ACCIDENT DOES OCCUR, SPRAY CAN PAINT IS AVAILABLE FROM YOUR NEAREST KEMLAN DEALER.

OPERATING HINTS

To get the best from your Kemlan heater it is essential that you use good firewood, and use it correctly. Many people do not understand the principle of using a wood burning appliance and we suggest that it will be worth your while to study the following extract from a well known American publication.

PRINCIPLES OF COMBUSTION: HOW WOOD BURNS

Technically, wood does not burn. What burns is the volatiles and charcoal that are created. That is why wood will not catch on fire immediately when you put a match to it; it has to first undergo the chemical changes that create the volatiles, and a match does not create enough heat to activate the process. As kindling and paper evaporate the moisture in the wood, the wood absorbs heat. At a certain point, gases are given off and when these volatiles reach 480 degrees F, or the "Flash point", as it is called, they will burst into flame if sufficient oxygen is present. The volatiles give off more heat than does charcoal, which is why a fire with flames (which burn the volatiles) produces more heat than one that is all charcoal.

Since the volatiles are gases and since heat rises, taking the gases with it, it is very easy to create a situation in which most of the volatiles go up the chimney almost as soon as they are produced. This is what happens with a roaring fire and, to a lesser extent, with an open fire. One of the reasons (but only one) that a freestanding wood stove produces more heat than an open fire is that the volatiles are contained within the firebox and are not so quickly dissipated up the chimney. A stove that is baffled is merely one that has interior construction design to keep the volatiles in the firebox longer; the longer they are in the firebox, the more completely they burn. The more completely they burn, the more heat is produced. It's that simple.

Since the flames burn the volatiles and produce heat, the ideal situation is the longest possible flame path. As soon as wood burners understand this, they tried to devise ways of making the flame path longer than in an ordinary open fire. Even though the role of oxygen in combustion was not understood in Ben Franklin's time, Franklin did realize the importance of more completely burned volatiles. His solution was to try to invent a downdraft stove – one that sent the volatiles back down through the fire – but he never succeeded in getting it to work. A downdraft goes against the nature of volatiles, which is to rise. In more recent times, there have been some successful downdraft – or partial downdraft – stoves created and some of the fireplace stoves and units utilise this principle. Ideally, it would be best if the volatiles could be redirected down through the fire several times, until they were almost totally consumed. This would not only make the maximum use of the heat potential of the wood; it would reduce creosote build-up to almost zero. Perhaps someday an ingenious inventor will design a unit that does this; so far no has been able to.

MOISTURE AND COMBUSTION

As we have seen, dry wood ignites faster and burns better – with higher heat production – than wet or green wood. The difference between the amount of heat produced by dry wood and green wood is so great that a dry softwood of good grade will produce more heat than green hardwood. Green white ash, for instance, is not as good a fuel as dry tamarack.

The reason for the superiority of dry wood is easy to understand. Heat cannot be produced until moisture has been driven off. Since even so-called seasoned dry wood contains approximately 20 percent moisture, it takes time for any fire to begin producing useable heat. Wet wood, which can have a moisture content of over 100 percent (due to the way moisture is measured), will take that much longer to produce heat. Meanwhile, the fire will produce smoke and creosote and very little heat. This was brought sharply to my attention when I installed my first wood heater. To my surprise and delight, I found it comfortably heated eight rooms, where I had expected to heat only two or three. After some time, when I had someone helping me run the fire, I suddenly noticed that the house was chilly. We added more wood and adjusted the draft controls, but nothing we did seemed to help. It finally occurred to me to check the woodpile. My friend had been getting green wood from a stack that was drying, instead of from the dry-wood stack. The difference the green wood made was so dramatic I will never forget it.

HOW TO TEST WOOD FOR DRYNESS

There are two easy ways for even a novice to spot dry wood. Dry wood tends to "check". Look at the log ends and you will see cracks radiating from the centre of the log. If the logs have been split, the cracks will be harder to find because wood tends to split along the cracks.

Another test for dry wood is the sound it makes when two logs are banged against each other. Green wood will make sort of a dull thud; dry wood makes a nice crisp, sharp sound. Once you have heard the two, you will remember the difference.

FROM THE ABOVE EXTRACT SEVERAL FACTS BECOME APPARENT:

1. It is vital that your firewood be dry and seasoned.
2. A good hot fire of kindling and smaller pieces of fuel must be established before adding larger logs.
3. The larger logs should be well alight before slowing down the combustion by adjusting the air intake.
4. A hot bed of coals needs to be maintained to ensure continued combustion in the firebox.
5. When new timber is added to the firebox the air control should be opened until the fuel is well alight before damping it down again. This will take from 10 to 20 minutes.
6. When setting the controls for overnight burn you will need to experiment with the settings to suit your particular type of fuel. Very dense hardwood requires more air to combust and over damping will result in charring and smoking causing the glass in the door to become dirty. The same will apply with fuel which is not fully seasoned or is not dry enough. Kemlan have followed a policy since 1969 of checking on all complaints about poor performance of their heaters and apart from a few instances of incorrect installation (mostly insufficient flue length) all problems have been directly related to incorrect operation and/or poor fuel. We know you will experience many years of satisfaction from your heater if you follow the above advice.

WARRANTY

1. Kemlan wood heaters carry a warranty on the 6mm firebox for a period of ten (10) years.
2. This warranty also covers other components of the heater for a period of one (1) year. These components include the baffle plate, handle assembly, secondary air tubes and fan.
3. Kemlan's warranty covers the wood heaters against defects in materials and manufacture.

4. THIS WARRANTY DOES NOT COVER –

- 4.1 Failure to comply with manufacturer's operation instructions.
- 4.2 Normal wear and tear or damage caused by incorrect installation.
- 4.3 Any form of rust and/or corrosion to the painted finish of the heater.
- 4.4 Damage to the glass in the door, if the damage is caused by impact or misuse.
- 4.5 The cost of collection and delivery of the wood heater and/or parts.
- 4.6 Damage caused by water ingress.
- 4.7 Cost of removal of defective heater or re-installation of replacement heater.
- 4.8 Failure to use fireplace components supplied by Kemlan Industries Pty Ltd.
- 4.9 Cost of inspection for damaged heater.

5. CLAIMS –

- 5.1 (i) Kemlan will provide a full replacement of the heater in the first five years after installation.
(ii) Replacement in the subsequent five years (i.e. sixth to tenth year after installation will be on the following basis.
Owner will pay fifty percent of purchase price if the claim is made in the sixth year – tenth year after purchase.
- 5.2 Replacement of heater subject to all conditions in section four of warranty.
- 5.3 Should any defects occur, contact the Kemlan distributor from whom you purchased the heater.
- 5.4 Under this warranty the defective parts will be repaired or replaced by Kemlan's option, free of charge.
6. The fireplace installation must comply with the relevant local statutes, ordinances, regulations and by-laws.

PLEASE COMPLETE AND RETAIN THIS SECTION FOR YOUR RECORDS

Purchased from:
Address:
Date of Purchase: